

# TMCM-1111 Hardware Manual

Hardware Version V1.10 | Document Revision V1.01 • 2017-OCT-10

The TMCM-1111 stepRocker servo is a single axis motor controller/driver board for 2-phase bipolar stepper motors. It supports S-shaped ramps in addition to linear ramps and closed-loop operation together with an external encoder.

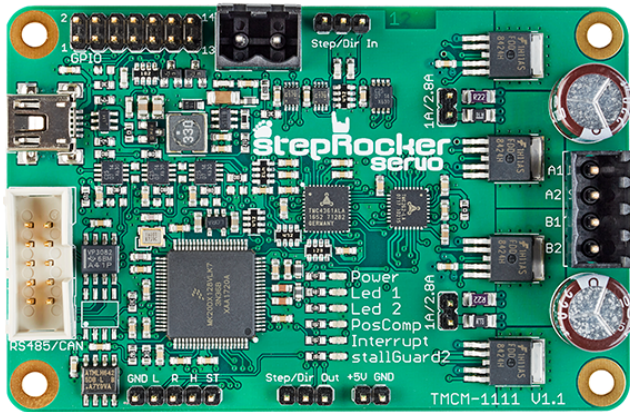

## Features

- Single axis controller/driver for 2-phase bipolar stepper motor
- S-shaped ramps + linear ramps
- Closed-loop operation with external encoder
- +10...30V DC supply voltage
- Up to 2.8A RMS motor current
- RS485 & USB interface
- multi-purpose inputs and outputs

## Applications

- Laboratory Automation
- Manufacturing
- Robotics
- Factory Automation
- Test & Measurement
- Technology evaluation
- First experiences with stepper motors
- Hobby applications

## Simplified Block Diagram

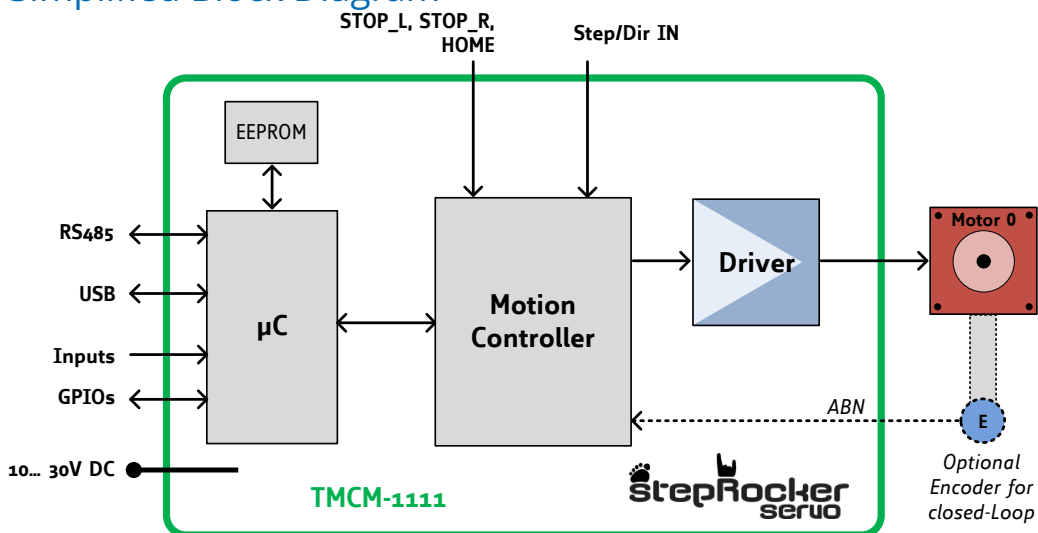

## Contents

<b>1</b>	<b>Features</b>	<b>3</b>
<b>2</b>	<b>Order Codes</b>	<b>4</b>
<b>3</b>	<b>Mechanical and Electrical Interfacing</b>	<b>5</b>
3.1	Size of board	5
<b>4</b>	<b>Connectors</b>	<b>6</b>
4.1	Power Connector	8
4.2	I/O Connector (Microcontroller)	8
4.3	Motor Connector	9
4.4	STOP_L, STOP_R and HOME Switch Connector	9
4.5	RS485 and CAN Connector	10
4.5.1	Upgrade the stepRocker for CAN communication	10
4.6	USB Connector	11
4.7	Step/Dir Input Connector	11
4.8	Step/Dir Output Connector	11
4.9	+5V Output Connector	12
4.10	Microcontroller Programming Interface	12
<b>5</b>	<b>Jumper Settings</b>	<b>13</b>
<b>6</b>	<b>LEDs</b>	<b>14</b>
<b>7</b>	<b>Communication</b>	<b>15</b>
7.1	RS485	15
7.2	USB	16
7.3	CAN (Retro-fit Option)	16
<b>8</b>	<b>Functional Description</b>	<b>18</b>
<b>9</b>	<b>Operational Ratings and Characteristics</b>	<b>19</b>
<b>10</b>	<b>Abbreviations used in this Manual</b>	<b>20</b>
<b>11</b>	<b>Figures Index</b>	<b>21</b>
<b>12</b>	<b>Tables Index</b>	<b>22</b>
<b>13</b>	<b>Supplemental Directives</b>	<b>23</b>
13.1	Producer Information	23
13.2	Copyright	23
13.3	Trademark Designations and Symbols	23
13.4	Target User	23
13.5	Disclaimer: Life Support Systems	23
13.6	Disclaimer: Intended Use	23
13.7	Collateral Documents & Tools	24
<b>14</b>	<b>Revision History</b>	<b>25</b>
14.1	Hardware Revision	25
14.2	Document Revision	25



# 1 Features

The TMCM-1111 stepRocker servo is a single axis motor controller/driver board for 2-phase bipolar stepper motors. It supports S-shaped ramps in addition to linear ramps and closed-loop operation together with an external encoder.

## Applications

- Highly compact single axis stepper motor controller/driver board for 2-phase bipolar stepper motors
- Linear and S-shaped ramps
- Closed-loop operation together with external encoder

## Electrical data

- Supply voltage: +24V DC (+10... +30V DC)
- Motor current: up to 1A RMS or 2.8A RMS (can be selected with jumpers)

## Mechanical data

- Board size: 85mm x 55mm, height 15mm max. without mating connectors
- 4 mounting holes for M3 screws

## Interfaces

- RS485 host interface
- USB 2.0 host interface (mini-USB connector)
- Step/Dir input (TTL level)
- Step/Dir output (+5V TTL level) for synchronisation (master-slave axes)
- 3 multi-purpose inputs (can be used for incremental ABN-encoder)
- STOP\_L, STOP\_R and HOME switch inputs
- START input / output for synchronized motion with several axes
- 6 multi-purpose I/Os
- 2 open-drain outputs
- $\mu$ C programming interface SWD (single wire debug / pads on PCB)
- Retro-fit option: CAN 2.0B communication interface

## Features

- TMC4361 stepper motor controller IC for on-the-fly alteration of many motion specific parameters, linear and S-shaped ramp and closed-loop support
- TMC262 advanced stepper motor driver IC with stallGuard2™ and coolStep™ features. Using the spreadCycle chopper the  $\mu$  step current sine wave is well formed with smooth zero crossing.
- support for left and right STOP and HOME switches
- EEPROM

## Software

- TMCL™ remote (direct mode) and standalone operation (memory for up to 1024 TMCL™ commands)
- Fully supported by TMCL-IDE (PC based integrated development environment)



## 2 Order Codes

The standard version of the stepRocker servo offers RS485 and USB interfaces (CAN transceiver **not** assembled).

The module is pre-programmed with TRINAMICs TMCL™ firmware with all available features.

Order Code	Description	Size (LxWxH)
TMCM-1111_V11 stepRocker servo	The stepRocker servo is a 1-axis bipolar stepper motor controller/driver module with optional closed-loop support and RS485 and USB interfaces	85mm x 55mm x 15mm

*Table 1: TMCM-1111\_V11 Order Code*



## 3 Mechanical and Electrical Interfacing

### 3.1 Size of board

The board with the controller/driver electronics has an overall size of 85mm x 55mm x 15mm without mating connectors. It offers four mounting holes for M3 screws (3.2mm diameter). All four mounting holes are connected to the ground plane (signal and supply ground) of the module.

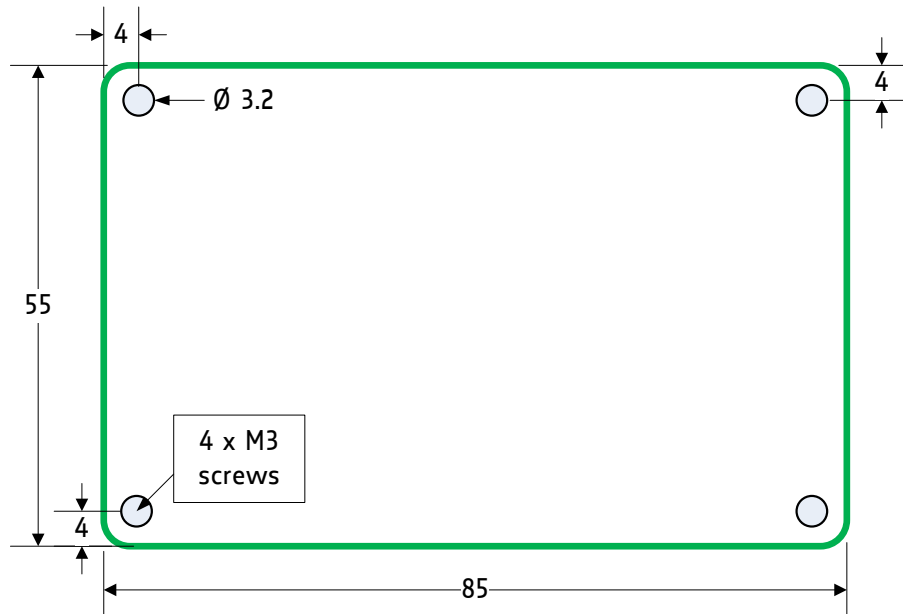

Figure 1: Board Dimensions and Position of Mounting Holes (all Values in mm)



## 4 Connectors

The TMCM-1111 stepRocker servo has eight connectors altogether. There are two screw connectors for power and motor and two interface connectors (mini-USB and RS485). Furthermore, the stepRocker has one connector for reference and home switches, one step/direction input connector (TTL level) and one output connector, and the GPIO connector, which can be used e.g. for connecting an ABN-encoder for closed-loop operation.

**NOTICE** Start with power supply OFF and do not connect or disconnect motor during operation! Motor cable and motor inductivity might lead to voltage spikes when the motor is (dis)connected while energized. These voltage spikes might exceed voltage limits of the driver MOSFETs and might permanently damage them. Therefore, always switch off / disconnect power supply or at least disable driver stage before connecting / disconnecting motor.

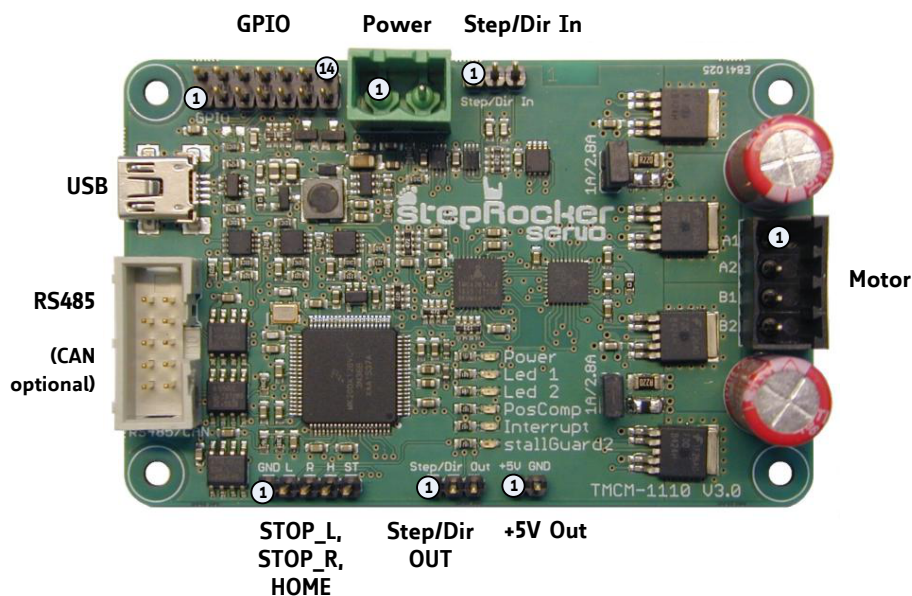

Figure 2: TMCM-1111 stepRocker Connectors

Connector Types and Mating Connectors		
Connector	Connector type on-board	Mating connector type
Power	RIA 220-02, 2 pin, 5.08mm pitch, shrouded header	RIA 249-02, screw type terminal block, pluggable, centerline 5.08mm pitch
Motor	RIA 183-04, 4 pin, 3.5mm pitch, shrouded header	RIA 169-04, screw type terminal block, pluggable, centerline 3.5mm pitch
USB	USB-mini female connector	USB-mini male connector
RS485/CAN	Low profile box header without locking bar, type 8380, 10 pin, DIN 41651, 2.54mm pitch	Low profile IDC socket connector, 10 pin, DIN 41651, 2.54mm pitch
GPIO	Multi-pin-connector, 14 pin, 2.54mm pitch	Female connector with 2.54mm pitch



Connector	Connector type on-board	Mating connector type
STOP_L, STOP_R, HOME	Multi-pin-connector, 5pin, 2.54mm pitch	Female connector with 2.54mm pitch
Step/Dir In	Multi-pin-connector, 3 pin, 2.54mm pitch	Female connector with 2.54mm pitch
Step/Dir Out	Multi-pin-connector, 3 pin, 2.54mm pitch	Female connector with 2.54mm pitch
+5V out	Two-pin-connector, 2.54mm pitch	Female connector with 2.54mm pitch

*Table 2: Connector Types and Mating Connectors of the TMC-1111 stepRocker servo*



## 4.1 Power Connector

Power Supply Connector Pin Assignment			
Pin	Label	Direction	Description
1	GND	Power (GND)	Common system supply and signal ground
2	10...30V	Power (input)	Power supply voltage

Table 3: Power Supply Connector Pin Assignment

### NOTICE

**Do not connect or disconnect motor during operation!** Motor cable and motor inductivity might lead to voltage spikes when the motor is (dis)connected while energized. These voltage spikes might exceed voltage limits of the driver MOSFETs and might permanently damage them. Therefore, always switch off / disconnect power supply or at least disable driver stage before connecting / disconnecting motor.

### NOTICE

**Take care of polarity, wrong polarity can destroy the board!**

## 4.2 I/O Connector (Microcontroller)

The TMC-1111 offers an on-board ARM Cortex-M4™ microcontroller with +3V3 powered IOs and +5V tolerant inputs. In order to be compatible with the original TMC-1110 stepRocker, +5V output level-shifters/buffers have been integrated on-board. This way, all general purpose IO pins configured as outputs will deliver +5V TTL signals.

Closed-loop operation with the TMC-1111 stepRocker servo requires an external encoder. The incremental ABN output signals of this encoder (either +5V TTL or open drain) have to be connected to the encoder input channels A, B and zero (pin 10, 12 and 14) of this I/O connector. The encoder channel inputs are connected to the on-board motion controller TMC4361 for closed loop support.

I/O Connector Pin Assignment			
Pin	Label	Direction	Description
1	GND	Power (GND)	Supply and signal ground
2	GND	Power (GND)	Supply and signal ground
3	PWMD_0	in/out	General purpose I/O (+5V compatible, default: input)
4	PWMU_0	in/out	General purpose I/O (+5V compatible, default: output)
5	PWMD_1	in/out	General purpose I/O (+5V compatible, default: input)
6	PWMU_1	in/out	General purpose I/O (+5V compatible, default: output)
7	PWMD_2	in/out	General purpose I/O (+5V compatible, default: input)
8	PWMU_2	in/out	General purpose I/O (+5V compatible, default: output)
9	AIN_0	in	Analog input (can be used as home switch) input voltage range 0...+10V, resolution: 12bit (0...4095)
10	PHASE_A	in	Encoder input channel A (+5V compatible, internal pull-up to +5V)





Pin	Label	Direction	Description
11	OpenDrain_1	out	Open-drain output (max. 100mA)
12	PHASE_B	in	Encoder input channel B (+5V compatible, internal pull-up to +5V)
13	OpenDrain_2	out	Open-drain output (max. 100mA)
14	PHASE_Z	in	Encoder input zero channel (+5V compatible, internal pull-up to +5V)

Table 4: I/O Connector Pin Assignment

### 4.3 Motor Connector

The motor has to be connected to the motor connector, one phase (phase A) between A1 and A2 and the second phase (phase B) between B1 and B2.

Motor Connector Pin Assignment			
Pin	Label	Direction	Description
1	A1	out	Pin 1 of motor coil A
2	A2	out	Pin 2 of motor coil A
3	B1	out	Pin 1 of motor coil B
4	B2	out	Pin 2 of motor coil B

Table 5: Motor Connector Pin Assignment

#### NOTICE

**Do not connect or disconnect motor during operation!** Motor cable and motor inductivity might lead to voltage spikes when the motor is (dis)connected while energized. These voltage spikes might exceed voltage limits of the driver MOSFETs and might permanently damage them. Therefore, always switch off / disconnect power supply or at least disable driver stage before connecting / disconnecting motor.

### 4.4 STOP\_L, STOP\_R and HOME Switch Connector

STOP_L, STOP_R and HOME Switch Connector Pin Assignment			
Pin	Label	Direction	Description
1	GND	Power (GND)	Signal and system ground
2	L	in	Input for left limit switch (STOP_L)
3	R	in	Input for right limit switch (STOP_R)
4	H	in	Input for home switch (HOME)



Pin	Label	Direction	Description
5	ST	in/out	Input or Output (programmable) for START signal of motion controller in order to synchronize motion of more than one stepRocker servo

Table 6: STOP\_L, STOP\_R and HOME Switch Connector Pin Assignment

### 4.5 RS485 and CAN Connector

The standard TMCM-1111 stepRocker offers the RS485 interface, only.

RS485/CAN Connector Pin Assignment			
Pin	Label	Direction	Description
1			
2			
3	CAN_L	bi-directional	differential CAN bus signal (inverting) - retro-fit option
4	CAN_H	bi-directional	differential CAN bus signal (non-inverting) - retro-fit option
5	GND	Power (GND)	Signal and system ground
6	RS485+	bi-directional	differential RS485 bus signal (non-inverting)
7	RS485-	bi-directional	differential RS485 bus signal (inverting)
8			
9			
10			

Table 7: RS485/CAN Connector Pin Assignment

#### 4.5.1 Upgrade the stepRocker for CAN communication

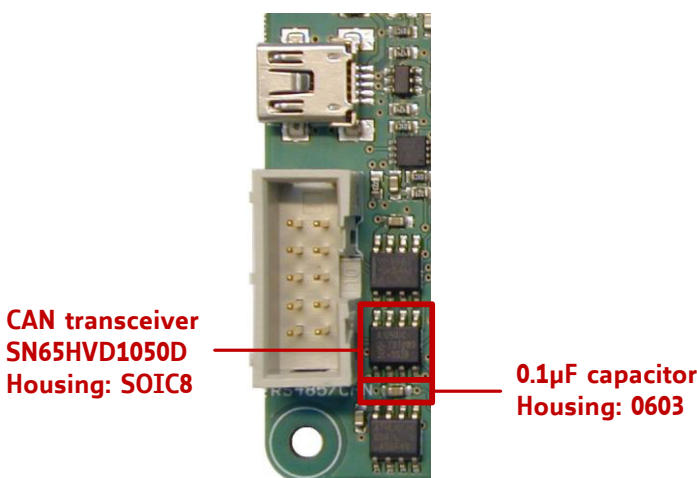

The table above shows the pin configuration for CAN, too. Before starting with CAN it is necessary to solder a SN65HVD1050D CAN transceiver with housing SOIC8 and a 0.1µ capacitor with housing 0603 on the TMCM-1111 stepRocker servo. Afterwards, the stepRocker is ready for using the CAN interface.

CAN and RS485 can be assembled at the same time. It is not necessary to remove the RS485 transceiver.



## 4.6 USB Connector

A USB interface is available via a mini-USB connector. This module supports USB 2.0 Full-Speed (12Mbit/s) connections.

USB Connector Pin Assignment			
Pin	Label	Direction	Description
1	VBUS	Power (+5V input)	+5V supply from the host
2	D-	bi-directional	USB Data-
3	D+	bi-directional	USB Data+
4	ID		Connected to signal and system ground
5	GND	Power (GND)	Signal and system ground

Table 8: USB Connector Pin Assignment

## 4.7 Step/Dir Input Connector

The TMC-1111 stepRocker servo is equipped with a step/dir input connector. Via this connector the on-board motion controller can be synchronized to an external master (e.g. adding closed-loop functionality). Please refer to firmware manual for options and more details.

Step/Dir Input Connector Pin Assignment			
Pin	Label	Direction	Description
1	GND	Power (GND)	Signal and System ground
2	Step In	in	Motion Controller step input signal (+5V compatible)
3	Dir In	in	Motion Controller direction input signal (+5V compatible)

Table 9: Step/Dir Input Connector Pin Assignment

## 4.8 Step/Dir Output Connector

Step-/Dir output signals from the on-board motion controller maybe connected to an external driver stage (e.g. with different voltage and / or current rating) or used for synchronisation of two or more axes (e.g. when connected to Step-/Dir Input of another stepRocker servo).

Step/Dir Output Connector Pin Assignment			
Pin	Label	Direction	Description
1	GND	Power (GND)	Signal and System ground
2	Step Out	out	Motion Controller step output signal (+5V compatible)
3	Dir Out	out	Motion controller direction output signal (+5V compatible)

Table 10: Step/Dir Output Connector Pin Assignment



### 4.9 +5V Output Connector

In contrast to the earlier generation stepRocker family TMCM-1110 the stepRocker servo integrates a switching DC/DC converter for generation of +5V digital supply on-board. This +5V are available also externally via the +5V Out Connector - delivering up-to 100mA e.g. for supply of an external encoder or home/end switch electronics.

+5V Output Connector Pin Assignment			
Pin	Label	Direction	Description
1	GND	Power (GND)	Signal and System ground
2	+5V out	out	+5V supply output. Can deliver up-to 100mA for external circuits e.g. encoder

Table 11: +5V Output Connector Pin Assignment

### 4.10 Microcontroller Programming Interface

The programming pads for the microcontroller are located on the bottom side of the module. They are connected directly to the related processor pins - resp. GND or on-board generated +3V3 supply. These pins are used for programming of the bootloader and firmware during production + testing of the module.

Programming Pads		
Pin	Label	Description
1	GND	Module and signal ground
2	+3V3	+3V3 DC supply - generated on-board
3	nRST	Hardware reset input
4	SWDIO	Serial wire data I/O
5	SWDCLK	Serial wire clock

Table 12: Programming Pads on Bottom of PCB

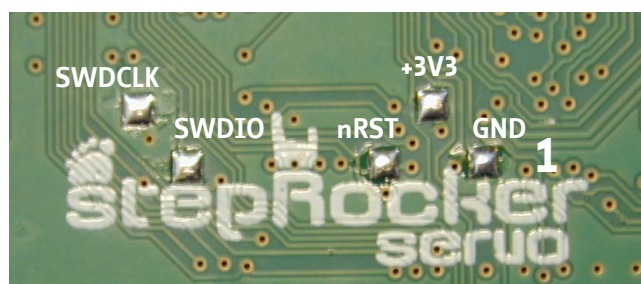

## 5 Jumper Settings

The TMCM-1111 stepRocker servo offers two jumpers for selection of programmable motor current range.

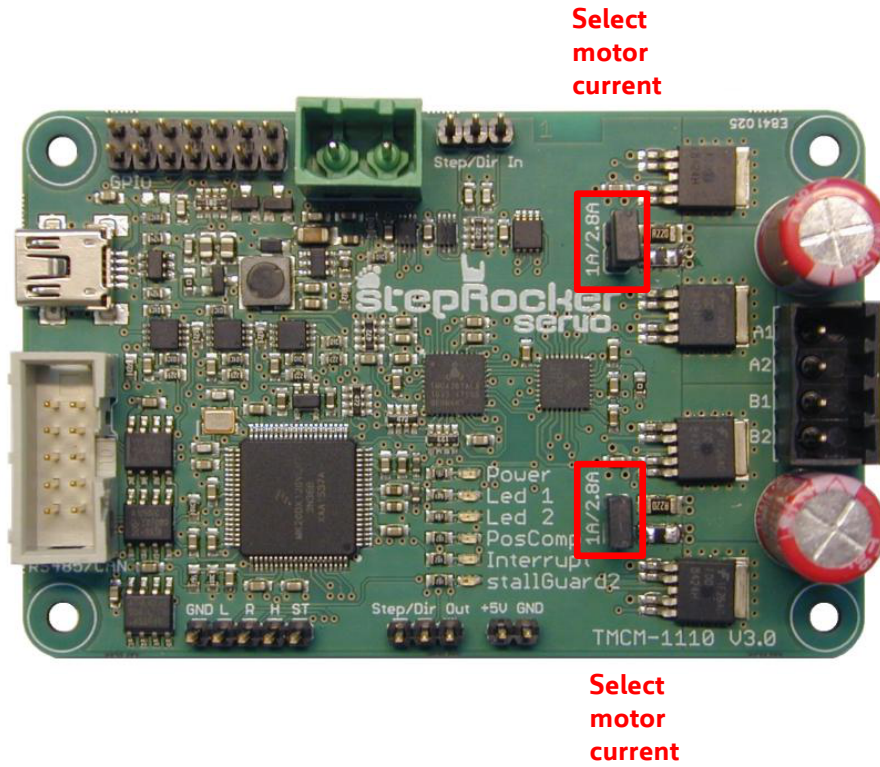

Figure 3: Jumper Settings of TMCM-1111 stepRocker servo

Jumpers of the TMCM-1111 stepRocker servo		
Jumper	Label	Description
Select motor current	1A/2.8A	Jumper plugged: motor current up to 2.8A RMS Jumper unplugged: motor current up to 1A RMS

Table 13: Jumpers of TMCM-1111 stepRocker servo



## 6 LEDs

LED Description		
Status	Label	Description
Power on	POWER	This orange LED lights up upon the power supply is available
LED1 without pre-defined functionality	LED1	This yellow LED can be used customer specific. This LED is connected to PTA5 (pin 31) of the MK20DX128VLK7 microcontroller.
LED2 without pre-defined functionality	LED2	This yellow LED can be used customer specific. This LED is connected to PTE5 (pin 6) of the MK20DX128VLK7 microcontroller.
POSCOMP output used	POSCOMP	This yellow LED lights up if the TARGET_REACHED output of the TMC4361 is activated.
Interrupt detected	Interrupt	This orange LED lights up upon interrupts. The LED is connected to the INTR pin of the TMC4361.
stallGuard2™ detected	stallGuard2	This red LED lights up upon stalling conditions. The LED is connected to the SG_TST pin of the TMC262.

Table 14: LED Description

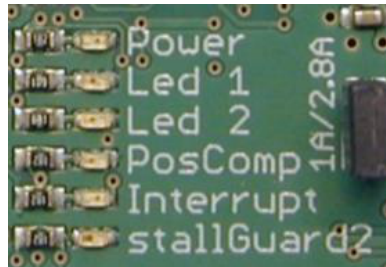

Figure 4: TMCM-1111 LEDs



## 7 Communication

### 7.1 RS485

For remote control and communication with a host system the TMCM-1111 provides a two wire RS485 bus interface. For proper operation the following items should be taken into account when setting up an RS485 network:

1. **BUS STRUCTURE:**

The network topology should follow a bus structure as closely as possible. That is, the connection between each node and the bus itself should be as short as possible. Basically, it should be short compared to the length of the bus.

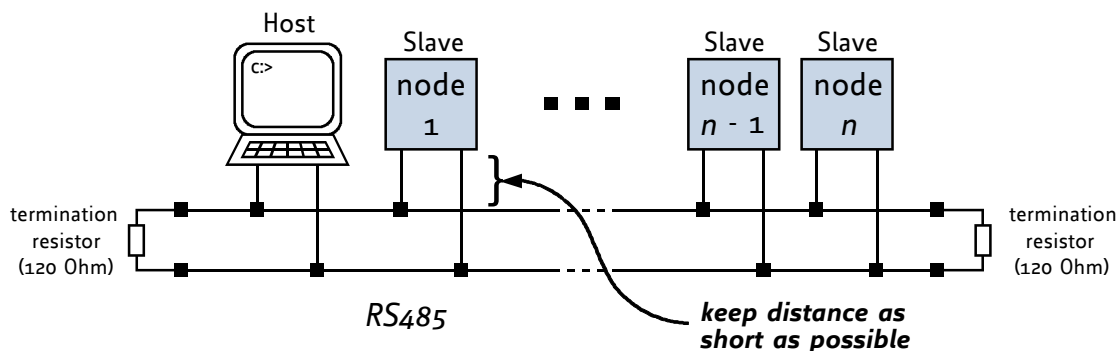

Figure 5: RS485 bus structure with termination resistors

2. **BUS TERMINATION:**

Especially for longer busses and/or multiple nodes connected to the bus and/or high communication speeds, the bus should be properly terminated at both ends. The TMCM-1111 does not integrate any termination resistor. Therefore, 120 Ohm termination resistors at both ends of the bus have to be added externally.

3. **NUMBER OF NODES:**

The RS485 electrical interface standard (EIA-485) allows up to 32 nodes to be connected to a single bus. The bus transceiver used on the TMCM-1111 units (SN65HVD3082ED) has just 1/8th of the standard bus load and allows a maximum of 256 units to be connected to a single RS485 bus.

4. **NO FLOATING BUS LINES:**

Avoid floating bus lines while neither the host/master nor one of the slaves along the bus line is transmitting data (all bus nodes switched to receive mode). Floating bus lines may lead to communication errors. In order to ensure valid signals on the bus it is recommended to use a resistor network connecting both bus lines to GND resp. +5V. In contrast to the termination resistors this network is normally required just once per bus. Certain RS485 interface converters available for PCs already include these additional resistors (e.g. USB-2-485).





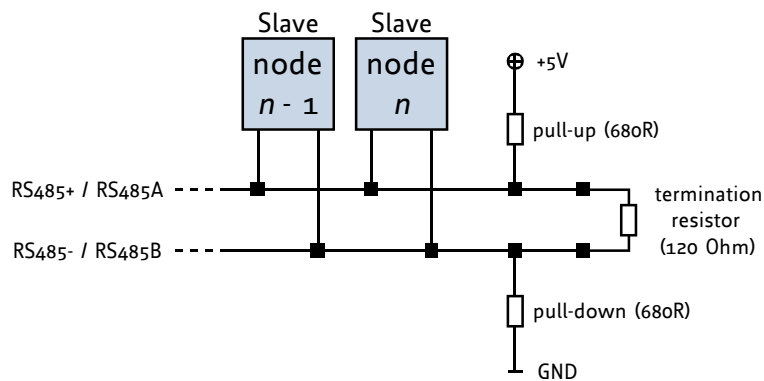

Figure 6: RS485 bus lines with resistor network

## 7.2 USB

For remote control and communication with a host system the TMCM-1111 stepRocker provides a USB 2.0 full-speed (12Mbit/s) interface (mini-USB connector). As soon as a USB-Host is connected the module will accept commands via USB. The TMCM-1111 supports USB self powered operation (External power supplied via the power supply connector) and USB bus powered operation, also (no external power is supplied via the power supply connector). During USB bus powered operation, only the core digital circuit parts will be operational. That is, the microcontroller itself and also the EEPROM. Of course, any motor movement will not be possible in this mode. This mode has been implemented in order to enable configuration / parameter setting / read-out, firmware updates etc. by just connecting a USB cable between the module and a host PC. No other connection / additional power supply is required.

## 7.3 CAN (Retro-fit Option)

For remote control and communication with a host system the TMCM-1111 stepRocker can be equipped with a CAN bus interface. Please note, that it is necessary to add CAN transceiver and filter capacitor first for the standard TMCM-1111 stepRocker version (see 4.5.1).

For proper operation the following items should be taken into account when setting up a CAN network:

### 1. BUS STRUCTURE:

The network topology should follow a bus structure as closely as possible. That is, the connection between each node and the bus itself should be as short as possible. Basically, it should be short compared to the length of the bus.

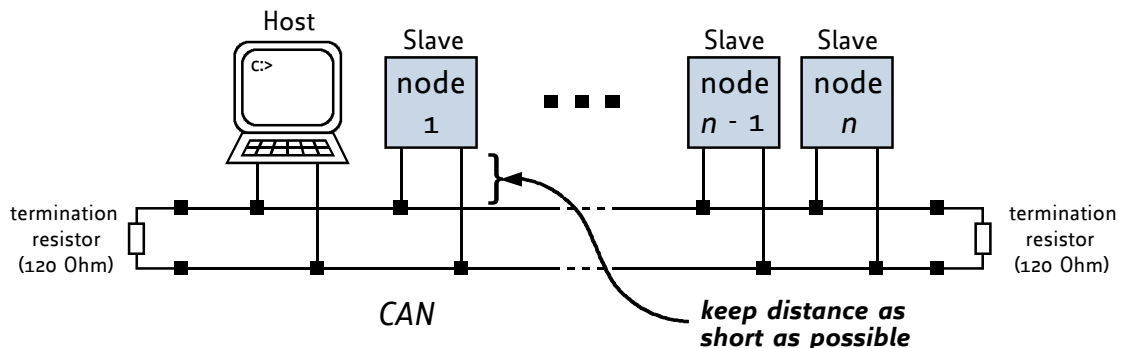

Figure 7: CAN bus structure with termination resistors





## 2. *BUS TERMINATION:*

Especially for longer busses and/or multiple nodes connected to the bus and/or high communication speeds, the bus should be properly terminated at both ends. The TMC-1111 does not integrate any termination resistor. Therefore, 120 Ohm termination resistors at both ends of the bus have to be added externally.



## 8 Functional Description

The TMCM-1111 stepRocker servo is a highly integrated single axis controller/driver module for stepper motors. The TMCM-1111 can be controlled via RS485 or USB serial interfaces (CAN retro-fit option). The TMCM-1111 comes with the PC based software development environment TMCL-IDE for the Trinamic Motion Control Language (TMCL™). Using predefined TMCL™ high level commands like *move to position* a rapid and fast development of motion control applications is guaranteed. Whereas the boot loader is installed during production and testing at TRINAMIC and remains usually untouched throughout the whole lifetime, the firmware can be updated by the user. Communication traffic is kept low since all time critical operations, e.g. ramp calculation, are performed on-board. Full remote control of the device with feedback is possible. The firmware of the module can be updated via any of the serial interfaces.

### The TMCM-1111 module contains the following main components:

- Microcontroller (ARM Cortex-M4™, MK20DX128VLK7), responsible for overall control and communication
- TMC4361 highly integrated advanced stepper motor controller. Supports linear and S-shaped ramps. Together with an external encoder closed-loop operation is supported.
- TMC262 advanced stepper motor driver IC with stallGuard2™ and coolStep™ with MOSFET driver stage (4x N+P power MOSFETs for bipolar stepper motor) for motor 0
- RS485 and USB transceivers
- On-board voltage regulators (+5V and +3V3) required for supply of all on-board digital circuits

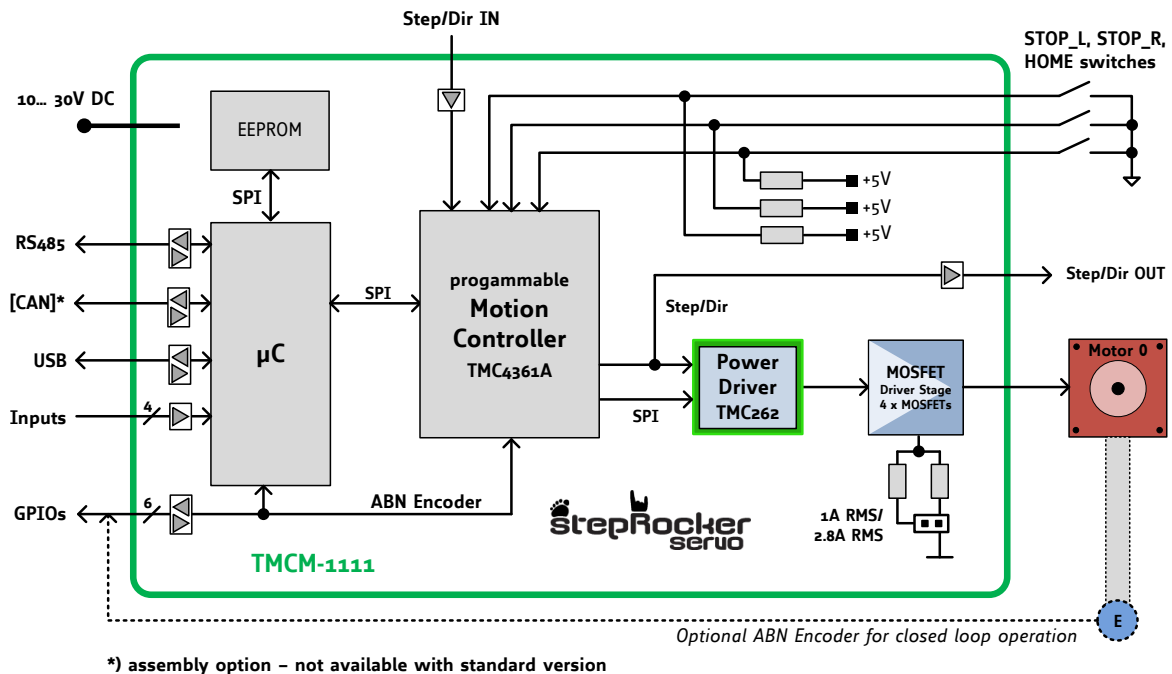

Figure 8: TMCM-1111 block diagram



## 9 Operational Ratings and Characteristics

### NOTICE

**Never Exceed the absolute maximum ratings!** Keep the power supply voltage below the upper limit of +30V! Otherwise the board electronics will seriously be damaged! Especially, when the selected operating voltage is near the upper limit a regulated power supply is highly recommended.

General Operational Ratings					
Symbol	Parameter	Min	Typ	Max	Unit
$V_{\text{Power}}$	Power supply voltage	10	12...24	30	V
$V_{\text{USB}}$	Power supply via USB connector		5		V
$I_{\text{USB}}$	Current withdrawn from USB supply when USB bus powered (no other supply connected)		70		mA
$I_{\text{COIL}}$	Motor coil current for sine wave <b>peak (chopper regulated, adjustable via software)</b>	0		1500 or 4000	mA
$I_{\text{MC}}$	Continuous motor current ( <b>RMS</b> )	0		1000 or 2800	mA
$T_{\text{ENV}}$	Environmental temperature at rated current (no forced cooling required)	-25		60	°C

Table 15: General operational ratings of the module

Operational Ratings of the RS485 Interface					
Symbol	Parameter	Min	Typ	Max	Unit
$N_{\text{RS485}}$	Number of nodes connected to single RS485 network			256	

Table 16: Operational ratings of the RS485 interface



## 10 Abbreviations used in this Manual

Abbreviation	Description
IDE	Integrated Development Environment
LED	Light Emmitting Diode
RMS	Root Mean Square value
TMCL	TRINAMIC Motion Control Language

*Table 17: Abbreviations used in this Manual*



## 11 Figures Index

1	Board Dimensions and Position of Mounting Holes (all Values in mm) . . .	5	5	RS485 bus structure with termination resistors . . . . .	15
2	TMCM-1111 stepRocker Connectors .	6	6	RS485 bus lines with resistor network	16
3	Jumper Settings of TMCM-1111 stepRocker servo . . . . .	13	7	CAN bus structure with termination resistors . . . . .	16
4	TMCM-1111 LEDs . . . . .	14	8	TMCM-1111 block diagram . . . . .	18



## 12 Tables Index

1	TMCM-1111_V11 Order Code . . . . .	4	11	+5V Output Connector Pin Assignment	12
2	Connector Types and Mating Connectors of the TMCM-1111 stepRocker servo . . . . .	7	12	Programming Pads on Bottom of PCB	12
3	Power Supply Connector Pin Assignment	8	13	Jumpers of TMCM-1111 stepRocker servo . . . . .	13
4	I/O Connector Pin Assignment . . . . .	9	14	LED Description . . . . .	14
5	Motor Connector Pin Assignment . . . . .	9	15	General operational ratings of the module . . . . .	19
6	STOP_L, STOP_R and HOME Switch Connector Pin Assignment . . . . .	10	16	Operational ratings of the RS485 interface . . . . .	19
7	RS485/CAN Connector Pin Assignment	10	17	Abbreviations used in this Manual . . . . .	20
8	USB Connector Pin Assignment . . . . .	11	18	Hardware Revision . . . . .	25
9	Step/Dir Input Connector Pin Assignment . . . . .	11	19	Document Revision . . . . .	25
10	Step/Dir Output Connector Pin Assignment . . . . .	11			



## 13 Supplemental Directives

### 13.1 Producer Information

### 13.2 Copyright

TRINAMIC owns the content of this user manual in its entirety, including but not limited to pictures, logos, trademarks, and resources. © Copyright 2017 TRINAMIC. All rights reserved. Electronically published by TRINAMIC, Germany.

Redistributions of source or derived format (for example, Portable Document Format or Hypertext Markup Language) must retain the above copyright notice, and the complete Datasheet User Manual documentation of this product including associated Application Notes; and a reference to other available product-related documentation.

### 13.3 Trademark Designations and Symbols

Trademark designations and symbols used in this documentation indicate that a product or feature is owned and registered as trademark and/or patent either by TRINAMIC or by other manufacturers, whose products are used or referred to in combination with TRINAMIC's products and TRINAMIC's product documentation.

This Hardware Manual is a non-commercial publication that seeks to provide concise scientific and technical user information to the target user. Thus, trademark designations and symbols are only entered in the Short Spec of this document that introduces the product at a quick glance. The trademark designation /symbol is also entered when the product or feature name occurs for the first time in the document. All trademarks and brand names used are property of their respective owners.

### 13.4 Target User

The documentation provided here, is for programmers and engineers only, who are equipped with the necessary skills and have been trained to work with this type of product.

The Target User knows how to responsibly make use of this product without causing harm to himself or others, and without causing damage to systems or devices, in which the user incorporates the product.

### 13.5 Disclaimer: Life Support Systems

TRINAMIC Motion Control GmbH & Co. KG does not authorize or warrant any of its products for use in life support systems, without the specific written consent of TRINAMIC Motion Control GmbH & Co. KG.

Life support systems are equipment intended to support or sustain life, and whose failure to perform, when properly used in accordance with instructions provided, can be reasonably expected to result in personal injury or death.

Information given in this document is believed to be accurate and reliable. However, no responsibility is assumed for the consequences of its use nor for any infringement of patents or other rights of third parties which may result from its use. Specifications are subject to change without notice.

### 13.6 Disclaimer: Intended Use

The data specified in this user manual is intended solely for the purpose of product description. No representations or warranties, either express or implied, of merchantability, fitness for a particular purpose



or of any other nature are made hereunder with respect to information/specification or the products to which information refers and no guarantee with respect to compliance to the intended use is given.

In particular, this also applies to the stated possible applications or areas of applications of the product. TRINAMIC products are not designed for and must not be used in connection with any applications where the failure of such products would reasonably be expected to result in significant personal injury or death (safety-Critical Applications) without TRINAMIC's specific written consent.

TRINAMIC products are not designed nor intended for use in military or aerospace applications or environments or in automotive applications unless specifically designated for such use by TRINAMIC. TRINAMIC conveys no patent, copyright, mask work right or other trade mark right to this product. TRINAMIC assumes no liability for any patent and/or other trade mark rights of a third party resulting from processing or handling of the product and/or any other use of the product.

### 13.7 Collateral Documents & Tools

This product documentation is related and/or associated with additional tool kits, firmware and other items, as provided on the product page at: [www.trinamic.com](http://www.trinamic.com).





## 14 Revision History

### 14.1 Hardware Revision

Version	Date	Author	Description
V1.0	2017-JAN-23	GE	Initial version
V1.1	2017-AUG-02	GE	Minor changes: plating added to mounting holes and resistor values of input dividers adapted in order to improve compatibility with version TMCM-1110

*Table 18: Hardware Revision*

### 14.2 Document Revision

Version	Date	Author	Description
0.90	2017-JUN-12	GE	First version
1.00	2017-SEP-06	GE	Minor corrections + adapted to hardware version 1.1
1.01	2017-OCT-10	OK	New product picture on first page.

*Table 19: Document Revision*

