

TMCM-1211 Hardware Manual

Hardware Version V1.10 | Document Revision V1.10 • 2018-NOV-06

The **TMCM-1211 StepRocker™** is a single axis motor controller/driver board for 2-phase bipolar stepper motors. It features the TRINAMIC motion controller/motor driver TMC5160 in combination with an ARM Cortex-M4™ (MK20DX128VLK7) processor. The Module is intended to be a fully functional development platform.

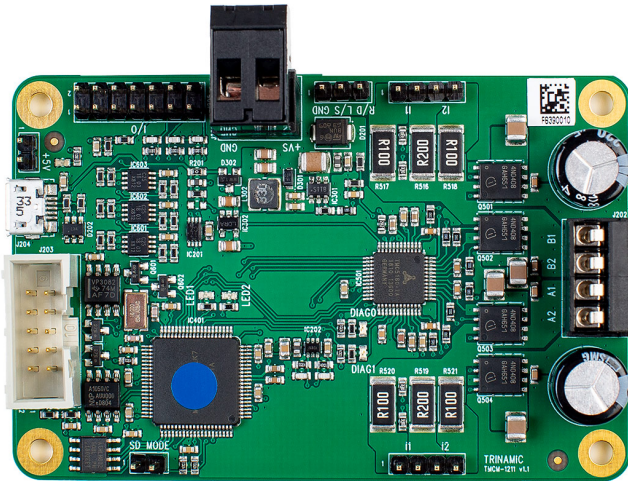

Features

- Single axis controller/driver for 2-phase bipolar stepper motor
- +10...30V DC supply voltage
- Up to 5.7A RMS motor current
- RS485 & USB interface
- Multi-purpose inputs and outputs

Applications

- Laboratory Automation
- Manufacturing
- Robotics
- Factory Automation
- Test & Measurement
- Technology evaluation
- First experiences with stepper motors
- Hobby applications

Simplified Block Diagram

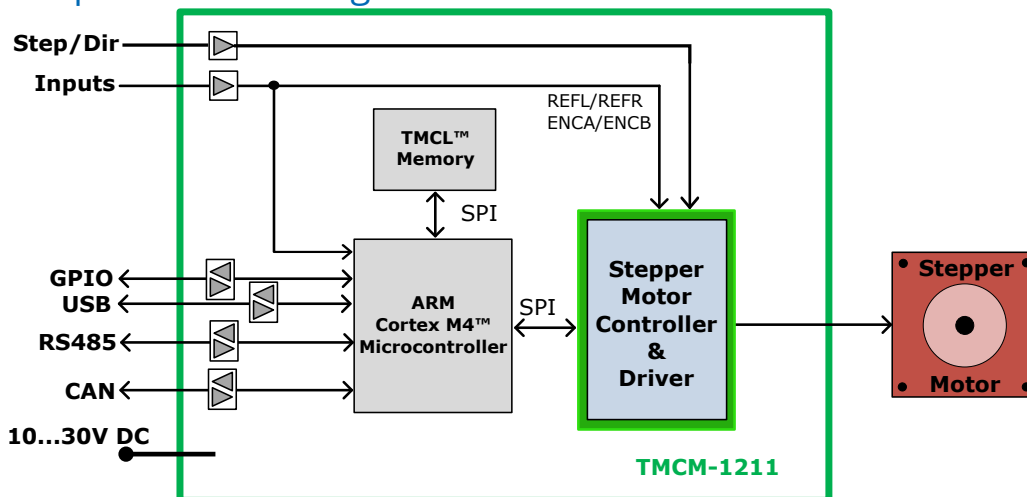

Contents

1 Features	3
2 Order Codes	4
3 Mechanical and Electrical Interfacing	5
3.1 Size of board	5
4 Connectors	6
4.1 Power Connector	7
4.2 I/O Connector (Microcontroller)	7
4.3 Motor Connector	8
4.4 Step/Dir Input + Reference Switches Connector	9
4.5 RS485 and CAN Connector	9
4.5.1 Upgrade the StepRocker™ for CAN communication	10
4.6 USB Connector	10
4.7 Microcontroller Programming Interface	10
5 Jumper Settings	12
6 LEDs	13
7 Communication	14
7.1 RS485	14
7.2 USB	15
7.3 CAN (Retro-fit Option)	15
8 Functional Description	17
9 Operational Ratings and Characteristics	18
10 Abbreviations used in this Manual	19
11 Figures Index	20
12 Tables Index	21
13 Supplemental Directives	22
13.1 Producer Information	22
13.2 Copyright	22
13.3 Trademark Designations and Symbols	22
13.4 Target User	22
13.5 Disclaimer: Life Support Systems	22
13.6 Disclaimer: Intended Use	22
13.7 Collateral Documents & Tools	23
14 Revision History	24
14.1 Hardware Revision	24
14.2 Document Revision	24



1 Features

The TMC5160 StepRocker™ is a single axis motor controller/driver board for 2-phase bipolar stepper motors. It features the TRINAMIC motion controller / motor driver TMC5160 in combination with an ARM Cortex-M4™ (MK20DX128VLK7) processor. The Module is intended to be a fully functional development platform.

Applications

- Highly compact single axis stepper motor controller/driver board for 2-phase bipolar stepper motors

Electrical data

- Supply voltage: +24V DC (+10... +30V DC)
- Motor current: up to 1.1A RMS, 3.4A RMS or 5.7A RMS (can be selected with jumpers)

Mechanical data

- Board size: 85mm x 55mm, height 15mm max. without mating connectors
- 4 mounting holes for M3 screws

Interfaces

- RS485 host interface
- USB 2.0 host interface (USB micro-B connector)
- Step/Dir input (TTL level)
- 3 multi-purpose inputs (can be used for ABN-encoder)
- 2 limit switch inputs (shared with Step/Dir inputs)
- 6 multi-purpose I/Os
- 2 open-drain outputs
- 1 analog input (0... 10V)
- µC programming interface SWD (single wire debug / pads on PCB)
- Retro-fit option: CAN 2.0B communication interface

Features

- TMC5160 integrated stepper motor controller and driver IC for 2-phase bipolar stepper motors
- stealthChop2™ for quiet movement
- spreadCycle™ chopper for highly dynamic motor control
- stallGuard2™ sensorless motor load detection
- coolStep™ current control for energy saving / reduced heat dissipation
- linear and sixPoint™ ramps with motion controller in hardware
- Up to 256 microsteps per fullstep
- EEPROM

Software

- TMCL™ remote (direct mode) and standalone operation (memory for up to 1024 TMCL™ commands)
- Fully supported by TMCL-IDE (PC based integrated development environment)



2 Order Codes

The standard version of the StepRocker™ has RS485 and USB interfaces (CAN transceiver **not** assembled). The module is pre-programmed with TRINAMICs TMCL™ firmware with all available features.

TMC-1211 Order Code		
Order Code	Description	Size (LxWxH)
TMC-1211 StepRocker	1-axis bipolar stepper motor controller/-driver module with RS485 and USB, 5.7A RMS, +24V	85mm x 55mm x 15mm

Table 1: TMC-1211 Order Code



3 Mechanical and Electrical Interfacing

3.1 Size of board

The board with the controller/driver electronics has an overall size of 85mm x 55mm x 15mm without mating connectors. It offers four mounting holes for M3 screws (3.2mm diameter). All four mounting holes are connected to the ground plane (signal and supply ground) of the module.

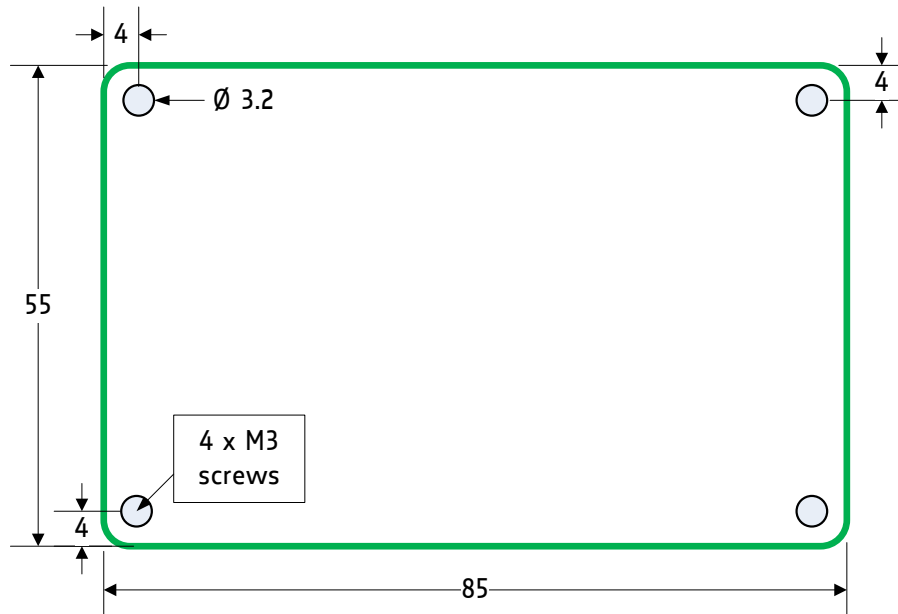

Figure 1: Board Dimensions and Positions of Mounting Holes (all Values in mm)



4 Connectors

The TMCM-1211 StepRocker™ has seven connectors altogether. There are two detachable screw connectors for power and motor and two interface connectors (micro-USB and RS485). Furthermore, the StepRocker offers one connector for step/direction and reference switch inputs, the GPIO connector, which can be used e.g. for connecting an ABN-encoder and one +5V supply output connector - e.g. for encoder or end switch supply.

NOTICE

Start with power supply OFF and do not connect or disconnect motor during operation! Motor cable and motor inductivity might lead to voltage spikes when the motor is (dis)connected while energized. These voltage spikes might exceed voltage limits of the driver MOSFETs and might permanently damage them. Therefore, always switch off / disconnect power supply or at least disable driver stage before connecting / disconnecting motor.

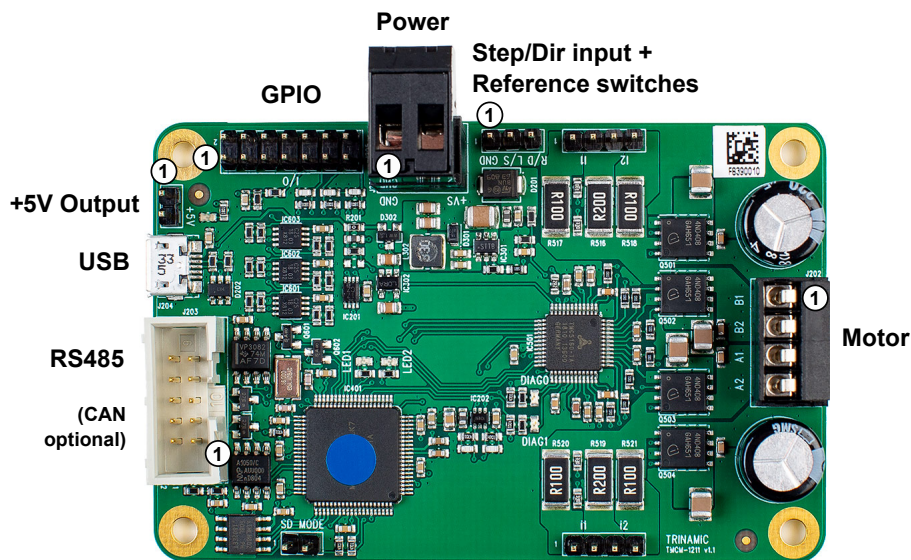

Figure 2: TMCM-1211StepRocker™ connectors

Connector Types and Mating Connectors		
Connector	Connector type on-board	Mating connector type
Power	RIA 220-02, 2 pin, 5.08mm pitch, shrouded header	RIA 249-02, screw type terminal block, pluggable, centerline 5.08mm pitch
Motor	RIA 183-04, 4 pin, 3.5mm pitch, shrouded header	RIA 169-04, screw type terminal block, pluggable, centerline 3.5mm pitch
USB	USB-micro-B female connector	USB-micro male connector
RS485/CAN	Low profile box header without locking bar, type 8380, 10 pin, DIN 41651, 2.54mm pitch	Low profile IDC socket connector, 10 pin, DIN 41651, 2.54mm pitch
GPIO	Header, 14 pin, 2.54mm pitch	Female connector with 2.54mm pitch



Connector	Connector type on-board	Mating connector type
Step/Dir input + reference switches	Header, 3pin, 2.54mm pitch	Female connector with 2.54mm pitch
+5V output	Header, 2 pin, 2.54mm pitch	Female connector with 2.54mm pitch

Table 2: Connector Types and Mating Connectors of the TMCM-1211 StepRocker™

4.1 Power Connector

Power Supply Connector Pin Assignment			
Pin	Label	Direction	Description
1	GND	Power (GND)	Common system supply and signal ground
2	10...30V	Power (input)	Power supply voltage

Table 3: Power Supply Connector Pin Assignment

NOTICE

Do not connect or disconnect motor during operation! Motor cable and motor inductivity might lead to voltage spikes when the motor is (dis)connected while energized. These voltage spikes might exceed voltage limits of the driver MOSFETs and might permanently damage them. Therefore, always switch off / disconnect power supply or at least disable driver stage before connecting / disconnecting motor.

NOTICE

Take care of polarity, wrong polarity can destroy the board!

4.2 I/O Connector (Microcontroller)

The TMCM-1211 offers an on-board ARM Cortex-M4™ microcontroller with +3V3 powered IOs and +5V tolerant inputs. In order to be compatible with previous generations (stepRocker™ TMCM-1110), +5V output level-shifters/buffers have been integrated on-board. This way, all general purpose IO pins configured as outputs will deliver +5V TTL signals.

I/O Connector Pin Assignment			
Pin	Label	Direction	Description
1	GND	Power (GND)	Supply and signal ground
2	GND	Power (GND)	Supply and signal ground
3	PWMD_0	in/out	General purpose I/O (+5V compatible, default: input)
4	PWMU_0	in/out	General purpose I/O (+5V compatible, default: output)
5	PWMD_1	in/out	General purpose I/O (+5V compatible, default: input)



Pin	Label	Direction	Description
6	PWMU_1	in/out	General purpose I/O (+5V compatible, default: output)
7	PWMD_2	in/out	General purpose I/O (+5V compatible, default: input)
8	PWMU_2	in/out	General purpose I/O (+5V compatible, default: output)
9	AIN_0	in	Analog input. Input voltage range: 0...+10V Resolution: 12bit (0...4095)
10	PHASE_A	in	Encoder input channel A (+5V compatible, internal pull-up to +5V)
11	OpenDrain_1	out	Open-drain output (max. 100mA)
12	PHASE_B	in	Encoder input channel B (+5V compatible, internal pull-up to +5V)
13	OpenDrain_2	out	Open-drain output (max. 100mA)
14	PHASE_Z	in	Encoder input zero channel (+5V compatible, internal pull-up to +5V)

Table 4: I/O Connector Pin Assignment

4.3 Motor Connector

The motor has to be connected to the motor connector, one phase (phase A) between A1 and A2 and the second phase (phase B) between B1 and B2.

Motor Connector Pin Assignment			
Pin	Label	Direction	Description
1	B1	out	Pin 1 of motor coil B
2	B2	out	Pin 2 of motor coil B
3	A1	out	Pin 1 of motor coil A
4	A2	out	Pin 2 of motor coil A

Table 5: Motor Connector Pin Assignment

NOTICE

Do not connect or disconnect motor during operation! Motor cable and motor inductivity might lead to voltage spikes when the motor is (dis)connected while energized. These voltage spikes might exceed voltage limits of the driver MOSFETs and might permanently damage them. Therefore, always switch off / disconnect power supply or at least disable driver stage before connecting / disconnecting motor.



4.4 Step/Dir Input + Reference Switches Connector

Step/Dir and Reference Switches Input Connector Pin Assignment			
Pin	Label	Direction	Description
1	GND	Power (GND)	Signal and system ground
2	REFL/STEP	in	Input for left reference/limit switch or driver step pulse signal
3	REFR/DIR	in	Input for right reference/limit switch or driver direction signal

Table 6: Step/Dir and Reference Switches Input Connector

4.5 RS485 and CAN Connector

The standard TMC-1211 StepRocker™ offers the RS485 interface, only.

RS485/CAN Connector Pin Assignment			
Pin	Label	Direction	Description
1			
2			
3	CAN_L	bi-directional	differential CAN bus signal (inverting) - retro-fit option
4	CAN_H	bi-directional	differential CAN bus signal (non-inverting) - retro-fit option
5	GND	Power (GND)	Signal and system ground
6	RS485+	bi-directional	differential RS485 bus signal (non-inverting)
7	RS485-	bi-directional	differential RS485 bus signal (inverting)
8			
9			
10			

Table 7: RS485/CAN Connector Pin Assignment



4.5.1 Upgrade the StepRocker™ for CAN communication

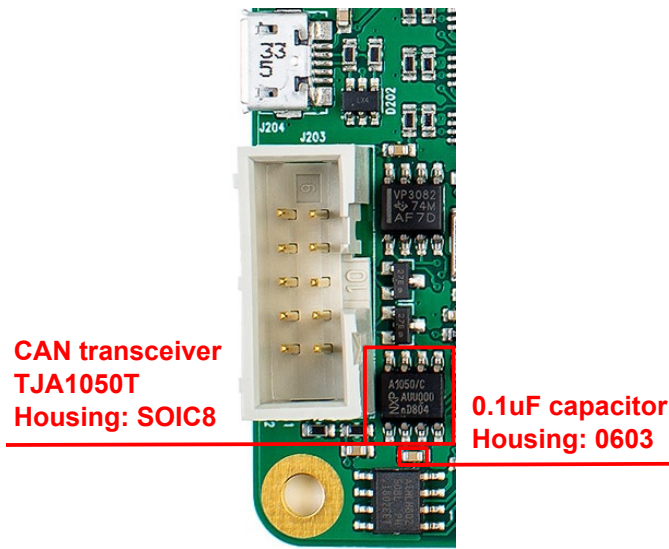

The table above shows the pin configuration for CAN, too. Before starting with CAN it is necessary to solder a TJA1050T CAN transceiver with housing SOIC8 and a 0.1µ capacitor with housing 0603 on the TMCM-1211 StepRocker™. Afterwards, the StepRocker™ is ready for using the CAN interface.

Because of the pin assignment CAN and RS485 can be used at the same time.

Please note: it is not necessary to remove the RS485 transceiver.

4.6 USB Connector

A USB interface is available via a micro-USB connector. This module supports USB 2.0 Full-Speed (12Mbit/s) connections.

USB Connector Pin Assignment			
Pin	Label	Direction	Description
1	VBUS	Power (+5V input)	+5V supply from the host
2	D-	bi-directional	USB Data-
3	D+	bi-directional	USB Data+
4	ID		not connected
5	GND	Power (GND)	Signal and system ground

Table 8: USB Connector Pin Assignment

4.7 Microcontroller Programming Interface

The programming pads for the microcontroller are located on the bottom side of the module. They are connected directly to the related processor pins - resp. GND or on-board generated +3V3 supply. These pins are used for programming of the bootloader and firmware during production + testing of the module.

Programming Pads		
Pin	Label	Description
1	GND	Module and signal ground
2	+3V3	+3V3 DC supply - generated on-board
3	nRST	Hardware reset input



Pin	Label	Description
4	SWDIO	Serial wire data I/O
5	SWDCLK	Serial wire clock

Table 9: Programming Pads on Bottom of the PCB

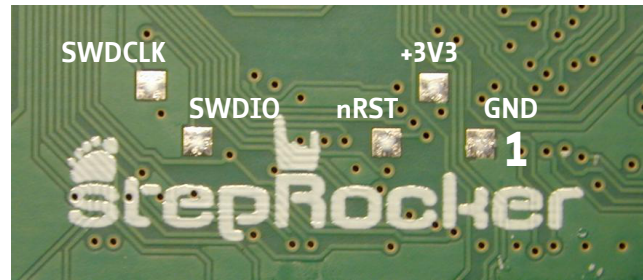

5 Jumper Settings

The TMCM-1211 StepRocker™ offers a number of jumpers for selection of different settings in hardware.

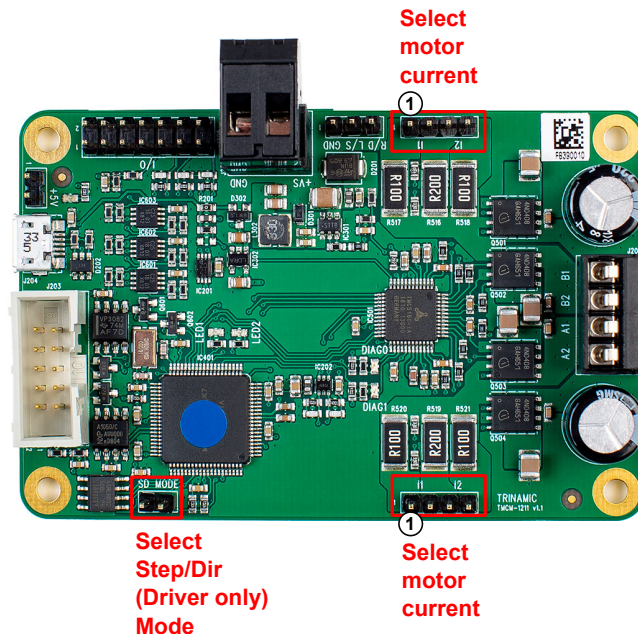

Figure 3: Jumper Settings of the TMCM-1211 StepRocker™

Jumpers of the TMCM-1211 StepRocker™		
Jumper	Label	Description
Select motor current	Jumper removed	Jumper removed: motor current up to 1.1A RMS
	Jumper pin 1-2	1 Jumper populated (pin 1-2): motor current up to 3.4A RMS
	Jumper pin 1-2 and 3-4	2 Jumper populated (pin 1-2 and pin 3-4): motor current up to 5.7A RMS
Select Step/Dir mode	Jumper removed	Remove jumper to enable on-board motion controller
	Jumper pin 1-2	Set jumpers to select external motion controller. Step/Dir Signals from external motion controller have to be connected to Step/Dir In

Table 10: Jumpers of the TMCM-1211 StepRocker™



6 LEDs

LED Description		
Status	Label	Description
Power on	+5V	This orange LED lights up upon the power supply is available
LED1 without pre-defined functionality	LED1	This yellow LED can be used customer specific. This LED is connected to PTA5 (pin 31) of the MK20DX128VLK7 microcontroller.
LED2 without pre-defined functionality	LED2	This yellow LED can be used customer specific. This LED is connected to PTE5 (pin 6) of the MK20DX128VLK7 microcontroller.
TMC5160 diagnosis output 0	DIAG_0	This green LED lights up if the DIAG 0 output of the TMC5160 is pulled low.
TMC5160 diagnosis output 1	DIAG_1	This green LED lights up if the DIAG 1 output of the TMC5160 is pulled low.

Table 11: LED Description

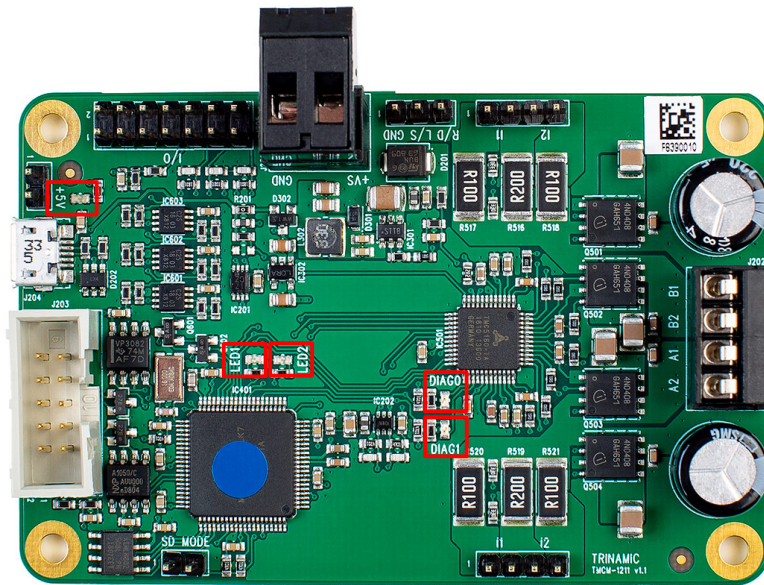

Figure 4: TCCM-1211 LEDs



7 Communication

7.1 RS485

For remote control and communication with a host system the TMCM-1211 provides a two wire RS485 bus interface. For proper operation the following items should be taken into account when setting up an RS485 network:

1. **BUS STRUCTURE:**

The network topology should follow a bus structure as closely as possible. That is, the connection between each node and the bus itself should be as short as possible. Basically, it should be short compared to the length of the bus.

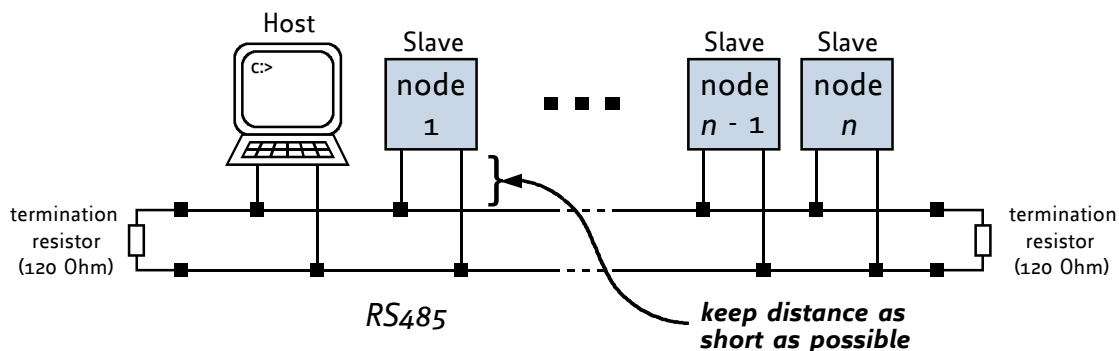

Figure 5: RS485 Bus Structure with Termination Resistors

2. **BUS TERMINATION:**

Especially for longer busses and/or multiple nodes connected to the bus and/or high communication speeds, the bus should be properly terminated at both ends. The TMCM-1211 does not intergate any termination resistor. Therefore, 120 Ohm termination resistors at both ends of the bus have to be added externally.

3. **NUMBER OF NODES:**

The RS485 electrical interface stadard (EIA-485) allows up to 32 nodes to be connected to a single bus. The bus transceiver used on the TMCM-1211 units (SN65HVD3082ED) has just 1/8th of the standard bus load and allows a maximum of 256 units to be connected to a single RS485 bus.

4. **NO FLOATING BUS LINES:**

Avoid floating bus lines while neither the host/master nor one of the slaves along the bus line is transmitting data (all bus nodes switched to receive mode). Floating bus lines may lead to communication errors. In order to ensure valid signals on the bus it is recommended to use a resistor network connecting both bus lines to GND resp. +5V. In contrast to the termination resistors this network is normally required just once per bus. Certain RS485 interface converters available for PCs already include these additional resistors (e.g. USB-2-485).



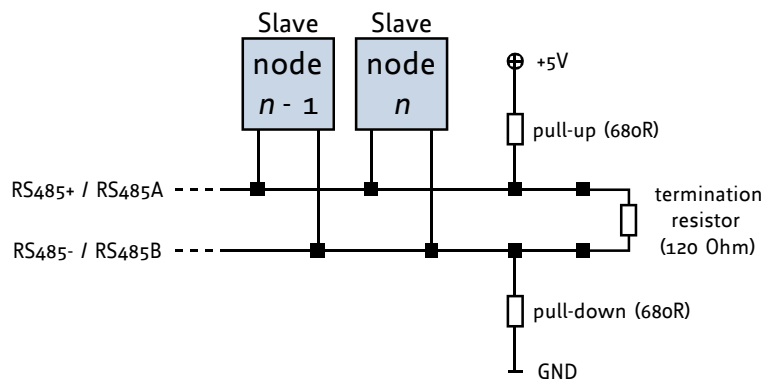

Figure 6: RS485 Bus Lines with Resistor Network

7.2 USB

For remote control and communication with a host system the TMCM-1211 StepRocker™ provides a USB 2.0 full-speed (12Mbit/s) interface (mini-USB connector). As soon as a USB-Host is connected the module will accept commands via USB. The TMCM-1211 supports USB self powered operation (External power supplied via the power supply connector) and USB bus powered operation, also (no external power is supplied via the power supply connector). During USB bus powered operation, only the core digital circuit parts will be operational. That is, the microcontroller itself and also the EEPROM. Of course, any motor movement will not be possible in this mode. This mode has been implemented in order to enable configuration / parameter setting / read-out, firmware updates etc. by just connecting a USB cable between the module and a host PC. No other connection / additional power supply is required.

7.3 CAN (Retro-fit Option)

For remote control and communication with a host system the TMCM-1211 StepRocker™ can be equipped with a CAN bus interface. Please note, that it is necessary to add CAN transceiver and filter capacitor first for the standard TMCM-1211 StepRocker™ version (see 4.5.1).

For proper operation the following items should be taken into account when setting up a CAN network:

1. BUS STRUCTURE:

The network topology should follow a bus structure as closely as possible. That is, the connection between each node and the bus itself should be as short as possible. Basically, it should be short compared to the length of the bus.

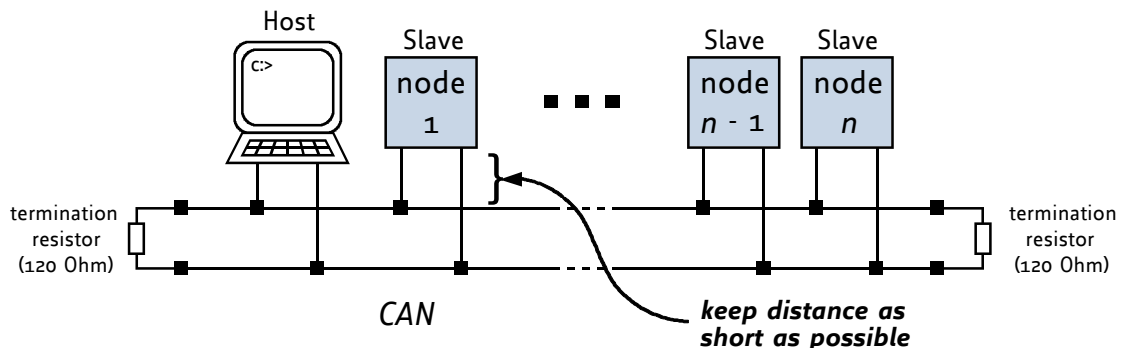

Figure 7: CAN Bus Structure with Termination Resistors



2. *BUS TERMINATION:*

Especially for longer busses and/or multiple nodes connected to the bus and/or high communication speeds, the bus should be properly terminated at both ends. The TMC-1211 does not integrate any termination resistor. Therefore, 120 Ohm termination resistors at both ends of the bus have to be added externally.



8 Functional Description

The TCCM-1211 is a highly integrated single axis controller/driver module for stepper motors. The TCCM-1211 can be controlled via RS485 or USB serial interfaces (CAN retro-fit option).

The TCCM-1211 comes with the PC based software development environment TMCL-IDE for the Trinamic Motion Control Language (TMCL™). Using predefined TMCL™ high level commands like *move to position* a rapid and fast development of motion control applications is guaranteed. Whereas the boot loader is installed during production and testing at TRINAMIC and remains usually untouched throughout the whole lifetime, the firmware can be updated by the user.

Communication traffic is kept low since all time critical operations, e.g. ramp calculation, are performed on-board. Full remote control of the device with feedback is possible. The firmware of the module can be updated via any of the serial interfaces.

The TCCM-1211 module contains the following main components:

- Microcontroller (ARM Cortex-M4™, MK20DX128VLK7), responsible for overall control and communication
- TMC5160 highly integrated stepper motor controller / driver. Step-/direction inputs, stop switch inputs and encoder inputs connected to TMC5160.
- MOSFET driver stage (8x NMOSFETs for bipolar stepper motor)
- RS485 and USB transceivers
- On-board voltage regulators (+5V and +3V3) required for supply of all on-board digital circuits

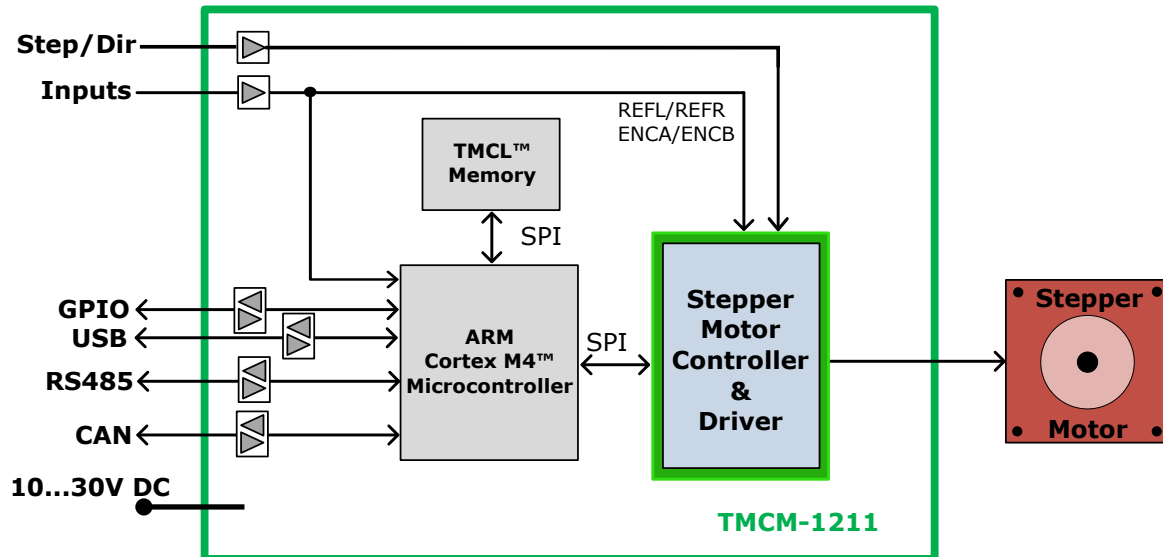

Figure 8: TCCM-1211 Block Diagram



9 Operational Ratings and Characteristics

NOTICE

Never Exceed the absolute maximum ratings! Keep the power supply voltage below the upper limit of +30V! Otherwise the board electronics will seriously be damaged! Especially, when the selected operating voltage is near the upper limit a regulated power supply is highly recommended.

General Operational Ratings					
Symbol	Parameter	Min	Typ	Max	Unit
V_{Power}	Power supply voltage	10	24	30	V
V_{USB}	Power supply via USB connector		5		V
I_{USB}	Current withdrawn from USB supply when USB bus powered (no other supply connected)		40		mA
I_{COIL}	Motor coil current for sine wave peak (chopper regulated, adjustable via software) with 0, 1 or 2 jumper set	0		1.6 or 4.8 or 8.1	A
I_{MC}	Continuous motor current (RMS) with 0, 1 or 2 jumper set	0		1.1 or 3.4 or 5.7	A
T_{ENV}	Environmental temperature at rated current (no forced cooling required)	-25		50	°C

Table 12: General Operational Ratings of the Module

Operational Ratings of the RS485 Interface					
Symbol	Parameter	Min	Typ	Max	Unit
N_{RS485}	Number of nodes connected to single RS485 network			256	

Table 13: Operational Ratings of the RS485 Interface



10 Abbreviations used in this Manual

Abbreviation	Description
IDE	Integrated Development Environment
LED	Light Emmitting Diode
RMS	Root Mean Square value
TMCL	TRINAMIC Motion Control Language

Table 14: Abbreviations used in this Manual



11 Figures Index

1	Board Dimensions and Positions of Mounting Holes (all Values in mm) . . .	5	5	RS485 Bus Structure with Termination Resistors	14
2	TMC-1211 StepRocker™ connectors	6	6	RS485 Bus Lines with Resistor Network	15
3	Jumper Settings of the TMC-1211 StepRocker™	12	7	CAN Bus Structure with Termination Resistors	15
4	TMC-1211 LEDs	13	8	TMC-1211 Block Diagram	17



12 Tables Index

1	TMCM-1211 Order Code	4	10	Jumpers of the TMCM-1211 StepRocker™	12
2	Connector Types and Mating Connectors of the TMCM-1211 StepRocker™	7	11	LED Description	13
3	Power Supply Connector Pin Assignment	7	12	General Operational Ratings of the Module	18
4	I/O Connector Pin Assignment	8	13	Operational Ratings of the RS485 Interface	18
5	Motor Connector Pin Assignment	8	14	Abbreviations used in this Manual	19
6	Step/Dir and Reference Switches Input Connector	9	15	Hardware Revision	24
7	RS485/CAN Connector Pin Assignment	9	16	Document Revision	24
8	USB Connector Pin Assignment	10			
9	Programming Pads on Bottom of the PCB	11			



13 Supplemental Directives

13.1 Producer Information

13.2 Copyright

TRINAMIC owns the content of this user manual in its entirety, including but not limited to pictures, logos, trademarks, and resources. © Copyright 2018 TRINAMIC. All rights reserved. Electronically published by TRINAMIC, Germany.

Redistributions of source or derived format (for example, Portable Document Format or Hypertext Markup Language) must retain the above copyright notice, and the complete Datasheet User Manual documentation of this product including associated Application Notes; and a reference to other available product-related documentation.

13.3 Trademark Designations and Symbols

Trademark designations and symbols used in this documentation indicate that a product or feature is owned and registered as trademark and/or patent either by TRINAMIC or by other manufacturers, whose products are used or referred to in combination with TRINAMIC's products and TRINAMIC's product documentation.

This Hardware Manual is a non-commercial publication that seeks to provide concise scientific and technical user information to the target user. Thus, trademark designations and symbols are only entered in the Short Spec of this document that introduces the product at a quick glance. The trademark designation /symbol is also entered when the product or feature name occurs for the first time in the document. All trademarks and brand names used are property of their respective owners.

13.4 Target User

The documentation provided here, is for programmers and engineers only, who are equipped with the necessary skills and have been trained to work with this type of product.

The Target User knows how to responsibly make use of this product without causing harm to himself or others, and without causing damage to systems or devices, in which the user incorporates the product.

13.5 Disclaimer: Life Support Systems

TRINAMIC Motion Control GmbH & Co. KG does not authorize or warrant any of its products for use in life support systems, without the specific written consent of TRINAMIC Motion Control GmbH & Co. KG.

Life support systems are equipment intended to support or sustain life, and whose failure to perform, when properly used in accordance with instructions provided, can be reasonably expected to result in personal injury or death.

Information given in this document is believed to be accurate and reliable. However, no responsibility is assumed for the consequences of its use nor for any infringement of patents or other rights of third parties which may result from its use. Specifications are subject to change without notice.

13.6 Disclaimer: Intended Use

The data specified in this user manual is intended solely for the purpose of product description. No representations or warranties, either express or implied, of merchantability, fitness for a particular purpose



or of any other nature are made hereunder with respect to information/specification or the products to which information refers and no guarantee with respect to compliance to the intended use is given.

In particular, this also applies to the stated possible applications or areas of applications of the product. TRINAMIC products are not designed for and must not be used in connection with any applications where the failure of such products would reasonably be expected to result in significant personal injury or death (safety-Critical Applications) without TRINAMIC's specific written consent.

TRINAMIC products are not designed nor intended for use in military or aerospace applications or environments or in automotive applications unless specifically designated for such use by TRINAMIC. TRINAMIC conveys no patent, copyright, mask work right or other trade mark right to this product. TRINAMIC assumes no liability for any patent and/or other trade mark rights of a third party resulting from processing or handling of the product and/or any other use of the product.

13.7 Collateral Documents & Tools

This product documentation is related and/or associated with additional tool kits, firmware and other items, as provided on the product page at: www.trinamic.com.



14 Revision History

14.1 Hardware Revision

Version	Date	Author	Description
V1.0	2018-JUN-21	MM	First version. Prototypes, only.
V1.1	2018-JUL-17	MM	Several corrections. Series version.

Table 15: Hardware Revision

14.2 Document Revision

Version	Date	Author	Description
1.00	2018-OCT-08	GE	First version
1.10	2018-NOV-06	GE	Several corrections (incl. order codes etc.)

Table 16: Document Revision

