

AC/DC power supplies JETA120



Features

- Class: Expert, power density up to **844 W/dm³**
- Low profile 21 mm design with blade solder pins; terminal blocks (optional) or mounting on DIN-rail (optional)
- Case operating temperature ranges: -40°C...+85°C, -50°C...+85°C
- Output current up to 24 A, output power 120 W; one, two or three output channels
- Input voltage ranges: 80...140 VAC, 100...242 VAC, 176...242 VAC
- Galvanically isolated output channels
- Over current, short circuit, overvoltage and thermal protection
- Max capacitance 120 000 µF (for U_{out}=5 VDC, 50% output power)
- Metal case

Description

AC/DC power supplies (modules) JETA120 are specially designed for industrial applications and harsh environment operation. This compact unit (111 x 61 x 21 mm) proven maximum output power of up to 120 W and it is available in versions with one, two or three **galvanically isolated** channels. The units can be switched on/off by a signal, have a full protection complex against over current, short circuit and overheating; they also can be connected in parallel or in series and provide compliance to EMC standard EN55022, class B.

JETA120-SxN, JETA120-SxP are part of "Industrial" line of products designed for a variety of industrial equipments and made of customized element base. They are sealed with heat-conducting potting material and could have wide operating temperature range up to -50°C...+85°C featuring a thermal protection chip. These power supplies undergo special temperature and burn-in tests with extreme on/off modes.

Ordering information

JETA 120 - 230W S 15 - S H N D

1 2 3 4 5 6 7 8 9

- 1 - «JETA» Series
- 2 - Max output power, W
- 3 - Input voltages
 - 115 - 115VAC (80...140 VAC)
 - 230W - 230 VAC (100...242 VAC)
 - 230 - 230 VAC (176...242 VAC)
- 4 - Index of output channels quantity
 - S - one
 - D - two
 - T - three
- 5 - Nominal output voltage, VDC (two signs for a channel)
- 6 - Index of design option
 - S - modification with polymer potting protection
- 7 - Index of case design and outputs
 - H - case with a cover and blade solder pins (basic version)
 - C - case with a cover and terminal blocks
- 8 - Index of operating temperature range of the case
 - N -40°C ...+85°C (basic version)
 - P -50°C ...+85°C
- 9 - Index of mounting on DIN-rail
 - D - with clip for mounting on DIN-rail

Technical information

Standard models with one output

Module	Input voltage range	Output power	Output voltage / nominal output current	Typical efficiency
JETA120-115S05-XXX	~80...140 VAC	80 W	5 VDC / 16 A	78%
JETA120-115S12-XXX			12 VDC / 6,67 A	82%
JETA120-115S15-XXX			15 VDC / 5,33 A	82%
JETA120-115S24-XXX			24 VDC / 3,33 A	84%
JETA120-115S27-XXX			27 VDC / 2,96 A	84%
JETA120-115S48-XXX			48 VDC / 1,67 A	84%
JETA120-230WS05-XXX	~100...242 VAC*	120 W	5 VDC / 24 A	80%
JETA120-230WS12-XXX			12 VDC / 10 A	84%
JETA120-230WS15-XXX			15 VDC / 8 A	84%
JETA120-230WS24-XXX			24 VDC / 5 A	86%
JETA120-230WS27-XXX			27 VDC / 4,44 A	86%
JETA120-230WS48-XXX			48 VDC / 2,5 A	86%
JETA120-230S05-XXX	~176...242 VAC	120 W	5 VDC / 24 A	80%
JETA120-230S12-XXX			12 VDC / 10 A	84%
JETA120-230S15-XXX			15 VDC / 8 A	84%
JETA120-230S24-XXX			24 VDC / 5 A	86%
JETA120-230S27-XXX			27 VDC / 4,44 A	86%
JETA120-230S48-XXX			48 VDC / 2,5 A	86%

Modules with non-standard output voltage from 5 to 60 VDC with maximal output current up to 24 A, could be delivered on request.

* For input voltage 230W (wide input) maximal output power decrease at input voltage 100...176 VAC according to the derating curves.

Standard models with two outputs

Module	Input voltage range	Output power	Output voltage / nominal output current	Typical efficiency
JETA120-115D0505-XXX	~80...140 VAC	80 W	5 VDC / 8 A ; 5 VDC / 8 A	77%
JETA120-115D0512-XXX			5 VDC / 8 A ; 12 VDC / 3,33 A	79%
JETA120-115D1212-XXX			12 VDC / 3,33 A ; 12 VDC / 3,33 A	81%
JETA120-115D1515-XXX			15 VDC / 2,67 A ; 15 VDC / 2,67 A	81%
JETA120-115D2727-XXX			27 VDC / 1,48 A ; 27 VDC / 1,48 A	83%
JETA120-230WD0505-XXX	~100...242 VAC*	120 W	5 VDC / 12 A ; 5 VDC / 12 A	79%
JETA120-230WD0512-XXX			5 VDC / 12 A ; 12 VDC / 5 A	81%
JETA120-230WD1212-XXX			12 VDC / 5 A ; 12 VDC / 5 A	83%
JETA120-230WD1515-XXX			15 VDC / 4 A ; 15 VDC / 4 A	83%
JETA120-230WD2727-XXX			27 VDC / 2,22 A ; 27 VDC / 2,22 A	85%
JETA120-230D0505-XXX	~176...242 VAC	120 W	5 VDC / 12 A ; 5 VDC / 12 A	79%
JETA120-230D0512-XXX			5 VDC / 12 A ; 12 VDC / 5 A	81%
JETA120-230D1212-XXX			12 VDC / 5 A ; 12 VDC / 5 A	83%
JETA120-230D1515-XXX			15 VDC / 4 A ; 15 VDC / 4 A	83%
JETA120-230D2727-XXX			27 VDC / 2,22 A ; 27 VDC / 2,22 A	85%

Modules with non-standard output voltage from 5 to 60 VDC with maximal output current up to 24 A, could be delivered on request.

* For input voltage 230W (wide input) maximal output power decreases at input voltage 100...176 VAC according to the derating curves.

Standard models with three outputs

Module	Input voltage range	Output power	Output voltage / nominal output current	Typical efficiency
JETA120-115T051212-XXX	~80...140 VAC	80 W	5 VDC / 8 A ; 12 VDC / 1,67 A ; 12 VDC / 1,67 A	79%
JETA120-115T051515-XXX			5 VDC / 8 A ; 15 VDC / 1,33 A ; 15 VDC / 1,33 A	79%
JETA120-230WT051212-XXX	~100...242 VAC*	120 W	5 VDC / 12 A ; 12 VDC / 2,5 A ; 12VDC / 2,5 A	81%
JETA120-230WT051515-XXX			5 VDC / 12 A ; 15 VDC / 2 A ; 15 VDC / 2 A	81%
JETA120-230T051212-XXX	~176...242 VAC	120 W	5 VDC / 12 A ; 12 VDC / 2,5 A ; 12 VDC / 2,5 A	81%
JETA120-230T051515-XXX			5 VDC / 12 A ; 15 VDC / 2 A ; 15 VDC / 2 A	81%

Modules with non-standard output voltage from 5 to 60 VDC with maximal output current up to 24 A, could be delivered on request.

* For input voltage 230W (wide input) maximal output power decreases at input voltage 100...176 VAC according to the derating curves.

Specifications for AC/DC power supplies JETA120*

Input specifications	
Input voltage range 115	~ 80...140 VAC (accepted=113...198V), ~ 80...140 VAC (accepted=113...198V),
Input voltage range / Input voltage transient deviation (1 s) 230 W**	~ 100...242 VAC (accepted=140...342V)/ ~ 100...264 VAC (accepted=140...373V)
Input voltage range / Input voltage transient deviation (1 s) 230	~ 176...242 VAC (accepted=248...342V)/ ~ 176...264 VAC (accepted=248...373V)
Input frequency	47...440 Hz
Input current surging at start-up	17 A for input voltage range 115, 33 A for input voltage range 230, 230W
Output specifications	
Instability of output voltage in accordance to changing of output current from 30 to 100% for single output model	±2%
Instability of output voltage in accordance to changing of output current from 30 to 100% for dual and triple output model	±2% for chan.1, ±7% for chan.2,3
Instability of output voltage in accordance to changing of output current from 30 to 100% for dual and triple output model with voltage difference between channels > 20%	±2% for chan.1, ±12% for chan.2,3
Instability of output voltage in accordance to instability of input voltage	±0,5% for chan. 1, ±1% for chan. 2, 3
Ripple and noise (peak-to-peak) (20 MHz)	<2% Uout
Short circuit protection***	>140% Iout nom, auto restore
Overvoltage protection***	>150% Uout
Over current protection level***	>120...140% Iout nom
Max capacitance for Uout=5 VDC, 50% Output power	120 000 µF****
General specifications	
Case temperature (operating N)	-40°C ...+85°C*****
Case temperature (operating P)	-50°C ...+85°C*****
Case temperature (storage)	-50°C ...+85°C
Level of operation of thermal protection (temperature of case)	82°C ...+95°C, auto restore
Output power derating (natural convection)	See diagram (dashed, dash-dotted curves)
Output power with heatsink with thermal resistnace Rha=0,56°C/W, difference between ambient and module case temperature would be 15°C	See diagram (solid curve)
High humidity	95% @ 35 °C
Conversion frequency, fixed	180 - 220 kHz
Insulation voltage input/case	~1500 VAC
Insulation voltage input/output	~3000 VAC
Insulation voltage output/case	~500 VAC
Insulation voltage output/output	=500 VDC
Isolation resistance @ 500 VDC	20 MΩ
EMC standards	EN55022, class B
Safety standard	IEC/EN60950
Thermal resistance case — environment without heat sink	4,8°C/W
Typical MTBF (Tcase = 50°C; Pout = 0,7 Pout max)	50 000 hrs
Cooling method	Free air convection or forced air cooling
Weight (max)	270 g

* All specifications are valid for normal climatic conditions, Uin.nom., Iout.nom., unless otherwise stated.

** For input voltage 230W (wide input) maximal output power decrease at input voltage 100...176 VAC according to the derating curves.

*** Parameters are stated for information purposes and could not be applied to long term work, exceeding maximum output current, at work outside of operating temperature range.

**** For other output voltages the maximum output capacity is calculated from the fact that $\frac{C_{max} \times U_{out}^2}{2}$ is a constant.

***** Turn-on delay of power supply at subzero temperatures can reach up to 5s at -40°C, 15...20s at -50°C.

Output power vs ambient temperature for input voltages ~176...242 VAC

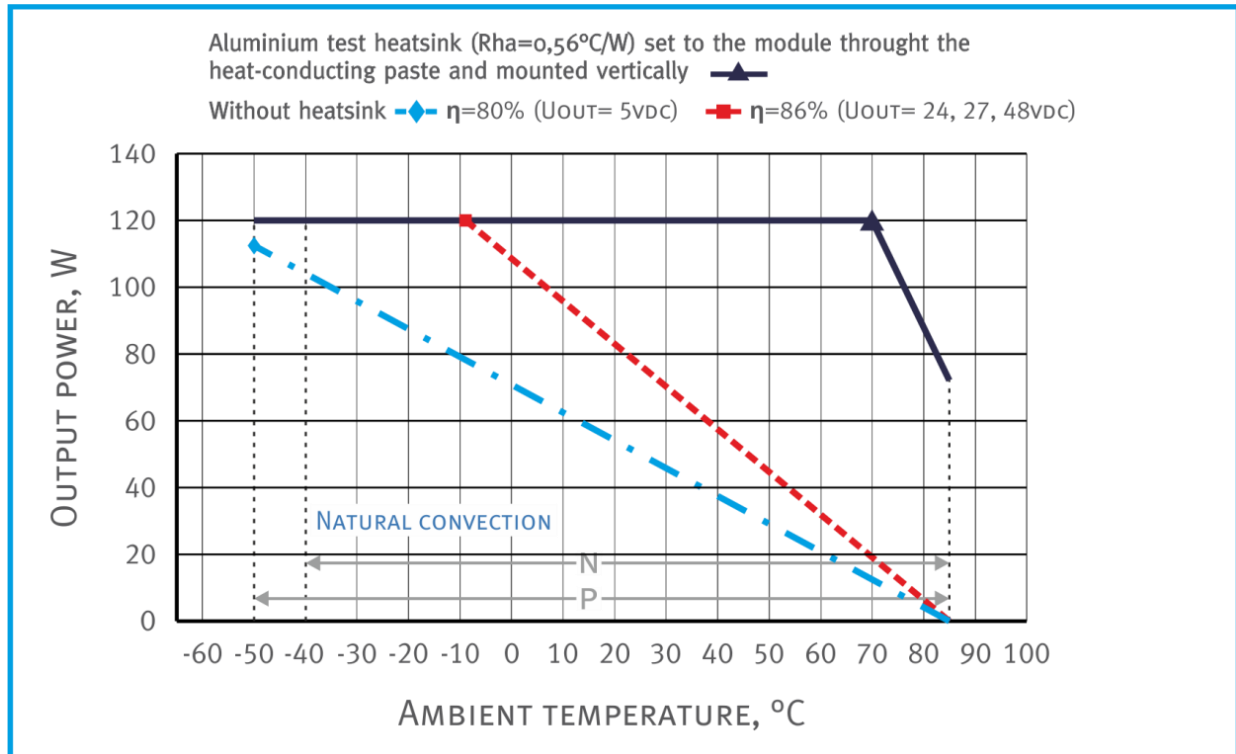

Dropping parts of the dashed and dash-dotted curves are in accordance with the **maximum temperature of the case** (for modules with index «N», «P» equal to $+85^{\circ}\text{C}$). Output power must not exceed the values which are limited by corresponding curve for a given ambient temperature.

Modules can be used without a heat sink only when attached to a heat conductive plate with thermal paste. The length and width of the plate should not be less than those of the case, and its thickness must not be less than 2 mm.

Points \blacktriangle , \blacklozenge and \blacksquare represent simultaneously several extreme worst-case conditions, such as the combination of maximum case temperature and maximum output power. Continuous module operation at these points should be avoided.

Output power vs input voltage for input voltages

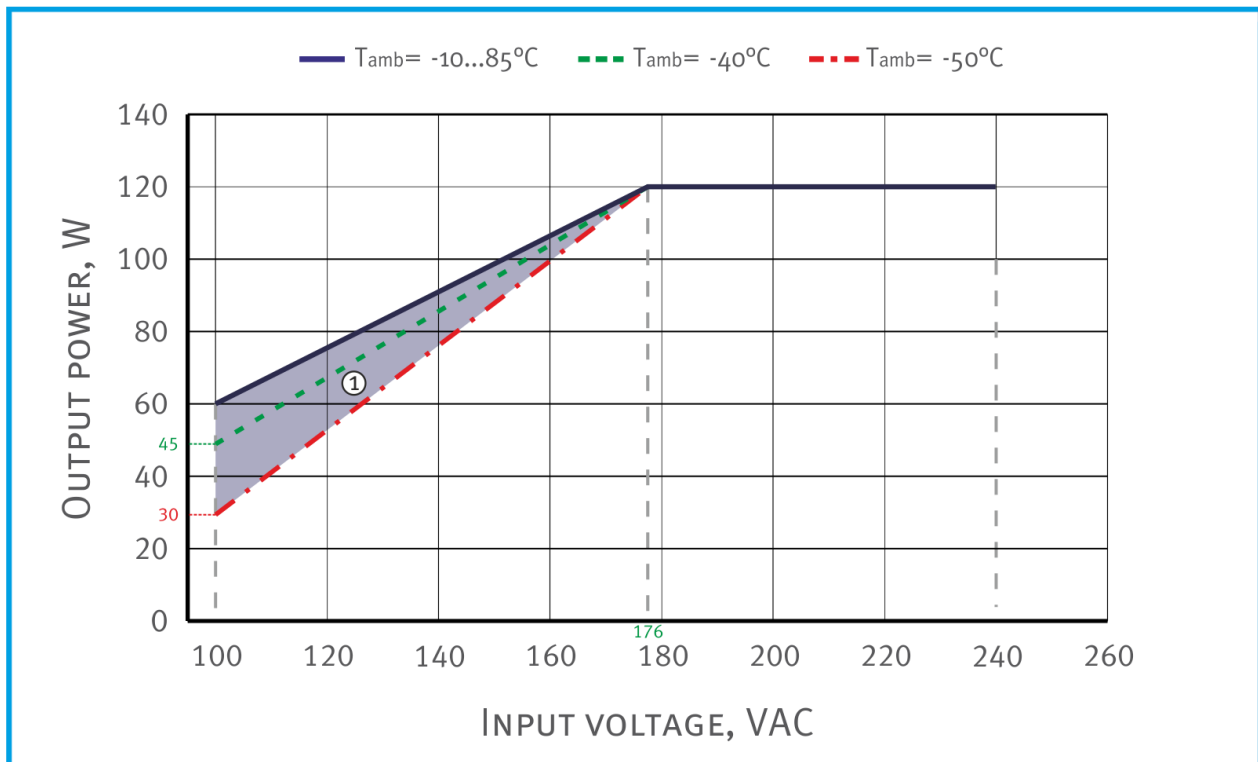

① - For ambient temperature $-50^{\circ}\text{C}...-10^{\circ}\text{C}$ in gray areas of diagrams some specification parameters may not be met.

Output power vs ambient temperature for input voltages 115

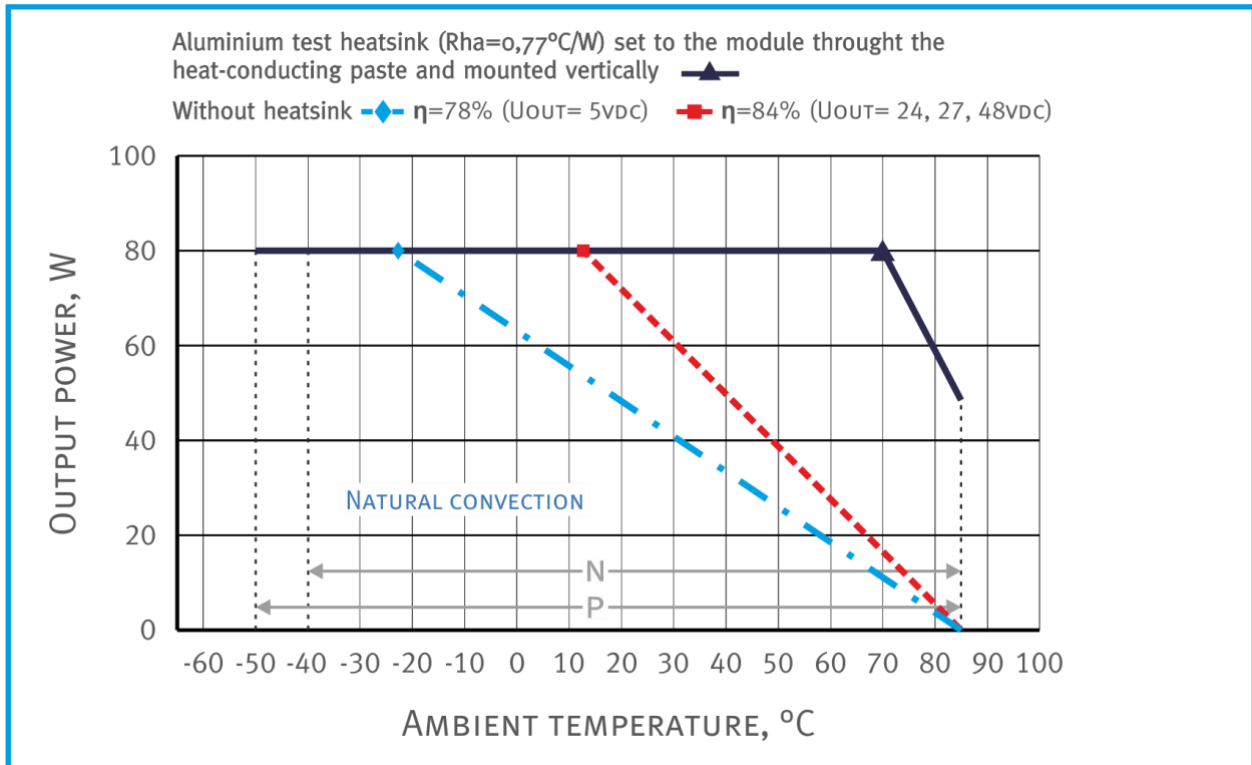

Dropping parts of the dashed and dash-dotted curves are in accordance with the **maximum temperature of the case** (for modules with index «N», «P» equal to $+85^{\circ}\text{C}$). Output power must not exceed the values which are limited by corresponding curve for a given ambient temperature.

Modules can be used without a heat sink only when attached to a heat conductive plate with thermal paste. The length and width of the plate should not be less than those of the case, and its thickness must not be less than 4 mm.

Points \blacktriangle , \blacklozenge and \blacksquare represent simultaneously several extreme worst-case conditions, such as the combination of maximum case temperature and maximum output power. Continuous module operation at these points should be avoided.

Output power vs input voltage for input voltages 115

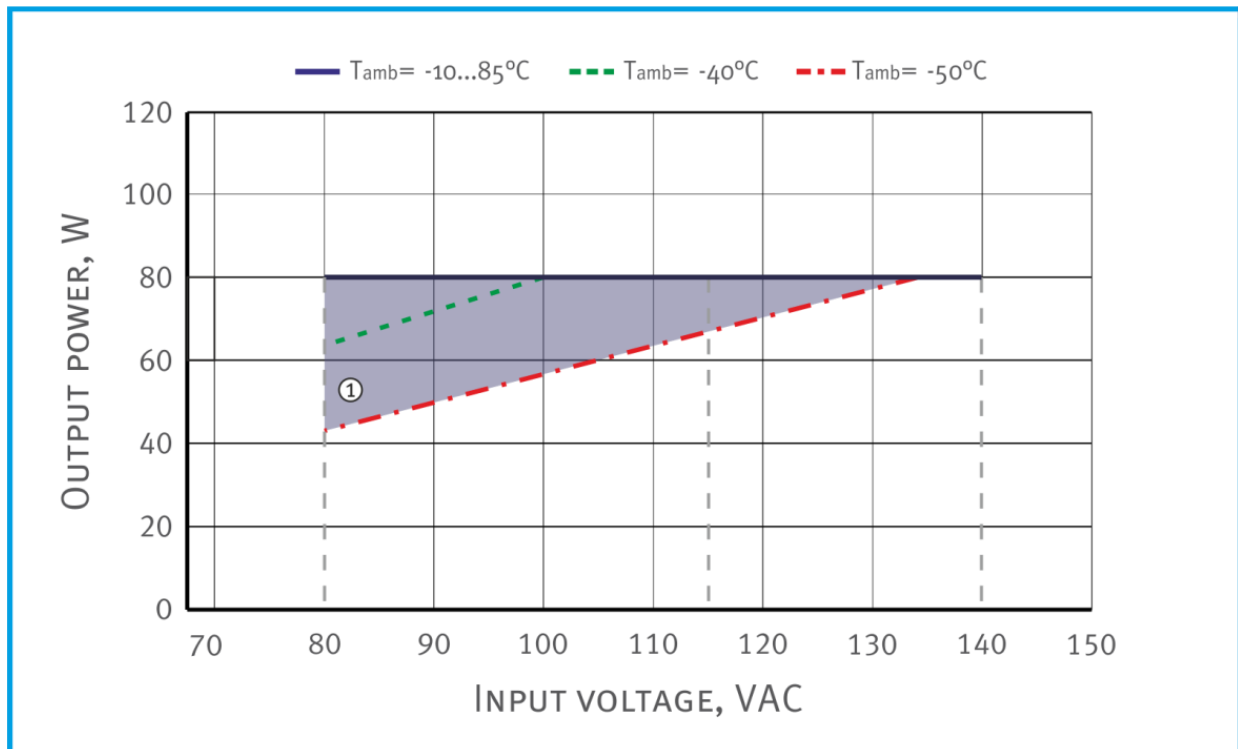

① - For ambient temperature $-50^{\circ}\text{C}\dots-10^{\circ}\text{C}$ in gray areas of diagrams some specification parameters may not be met.

Pin out (models with blade solder pins)

Nº Pin	1	2	3	4	5	6	7	8	9
Single output	GND	L	N	+OUT1	-OUT1	-	-	-	-
Dual output	GND	L	N	+OUT1	+OUT1	-OUT1	-OUT1	+OUT2	-OUT2
Triple output	GND	L	N	+OUT1	-OUT1	+OUT2	-OUT2	+OUT3	-OUT3

Single output model with blade solder pins (II A case size)

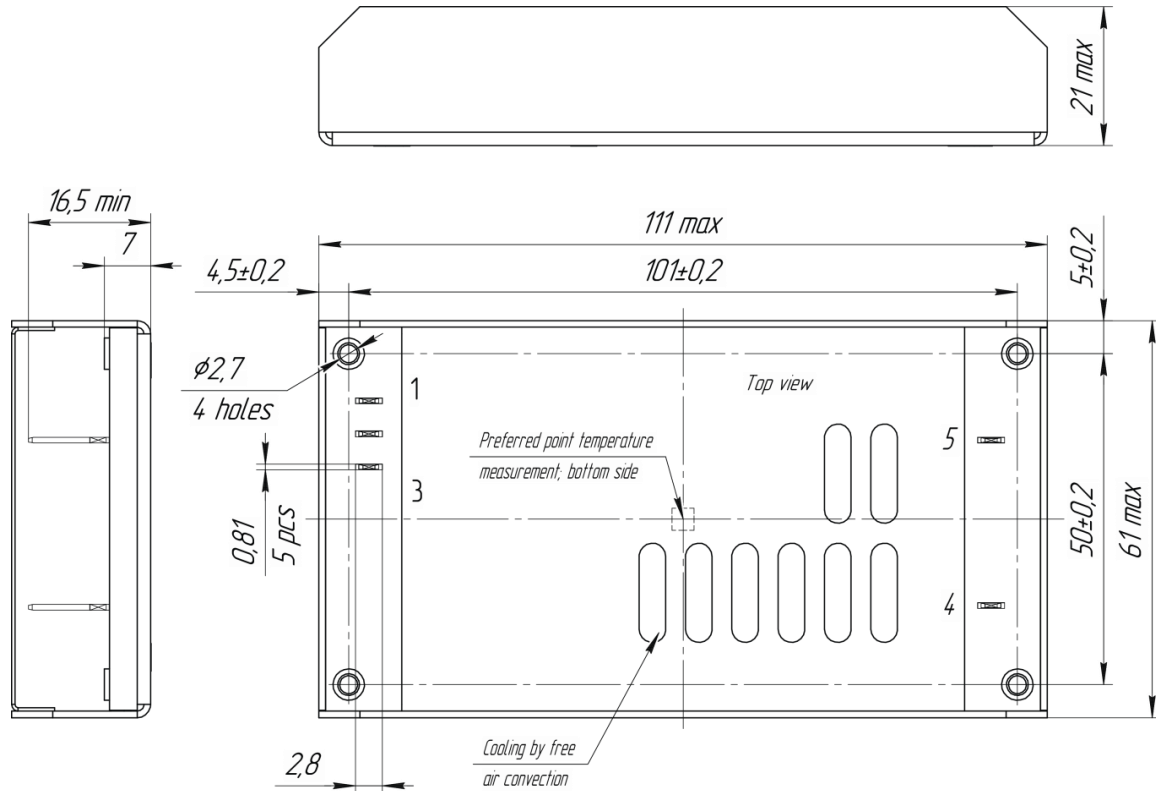

Dual output model with blade solder pins (II A case size)

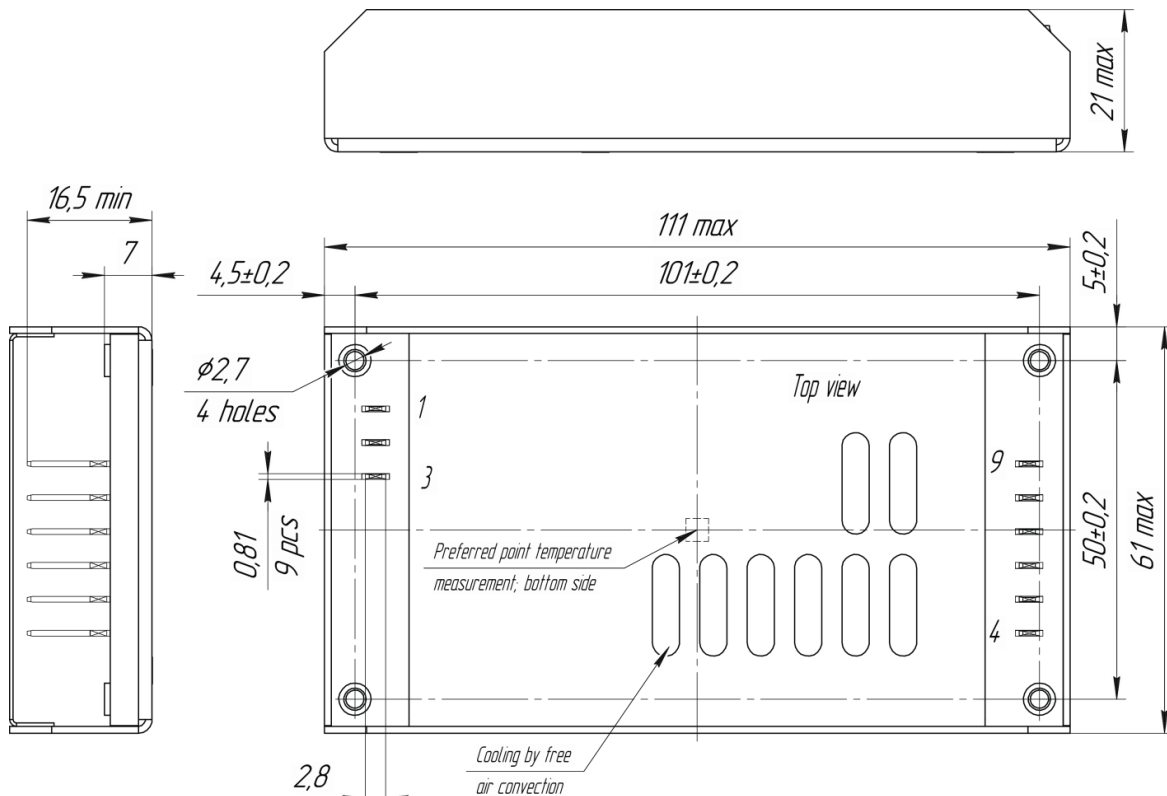

Triple output model with blade solder pins (II A case size)

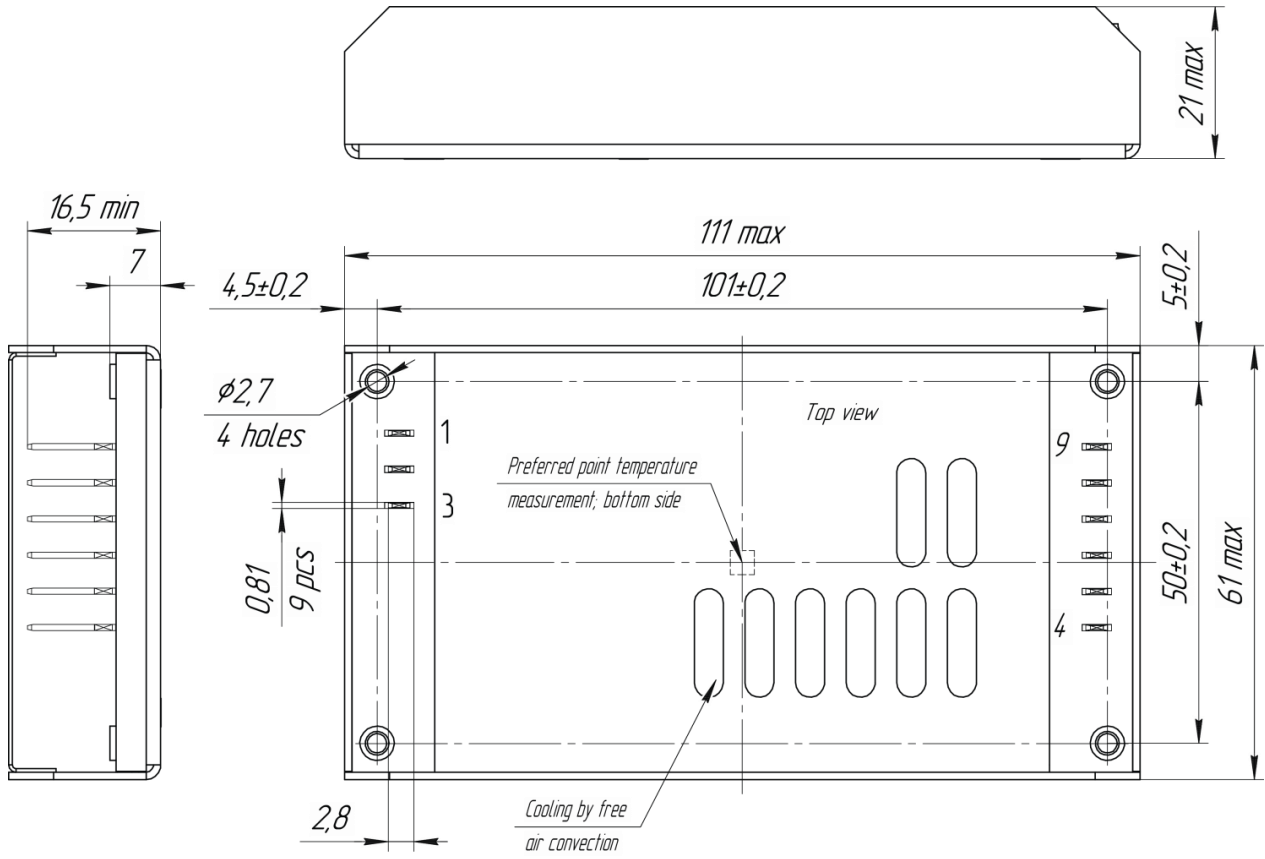

Pin out (models with terminal blocks)

Nº Pin	X1.1	X1.2	X1.3	X2.1	X2.2	X2.3	X2.4	X2.5	X2.6
Single output	GND	L	N	+OUT1	-OUT1	—	—	—	—
Dual output	GND	L	N	+OUT1	+OUT1	-OUT1	-OUT1	+OUT2	-OUT2
Triple output	GND	L	N	+OUT1	-OUT1	+OUT2	-OUT2	+OUT3	-OUT3

X1	RATED WIRE SIZE SOLID: max.: 3.3mm² Stranded (flexible): max.: 3.3mm² Stranded with Ferrule: max 3.3mm² Screw size: M3 Torque: 0,5 Nm
X2.1 X2.2	Screw size: 6-32 x 1/4L Recommended torque: 0.5Nm Recommended: Use ring terminal, for example MOLEX 19323-0007, MOLEX 19324-0007

Single output model with terminal blocks (II A case size)

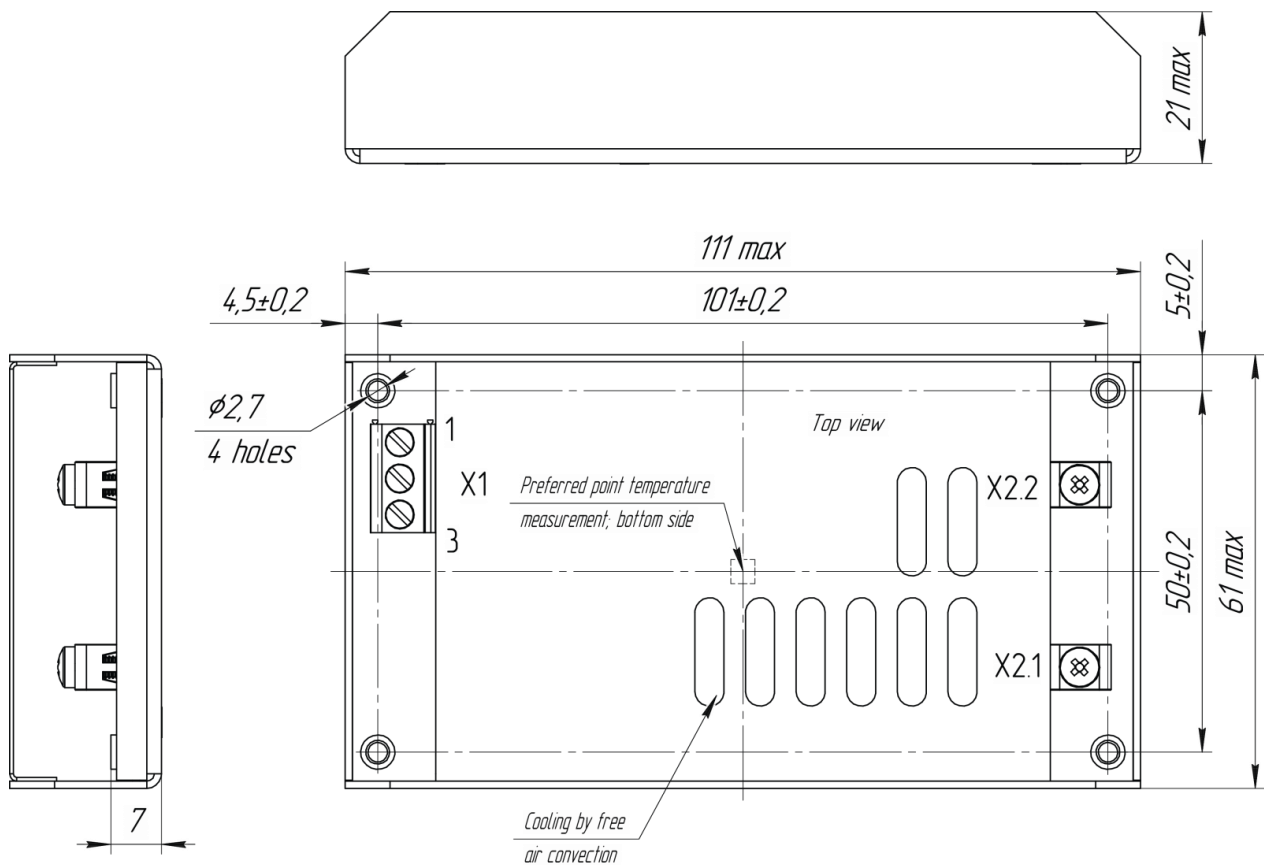

Dual output model with terminal blocks (II A case size)

<p>X1 X2.1...X2.6</p>	<p>RATED WIRE SIZE SOLID: max.: 3.3mm² Stranded (flexible): max.: 3.3mm² Stranded with Ferrule: max 3.3mm² Screw size: M3 Torque: 0,5 Nm</p>
---------------------------	--

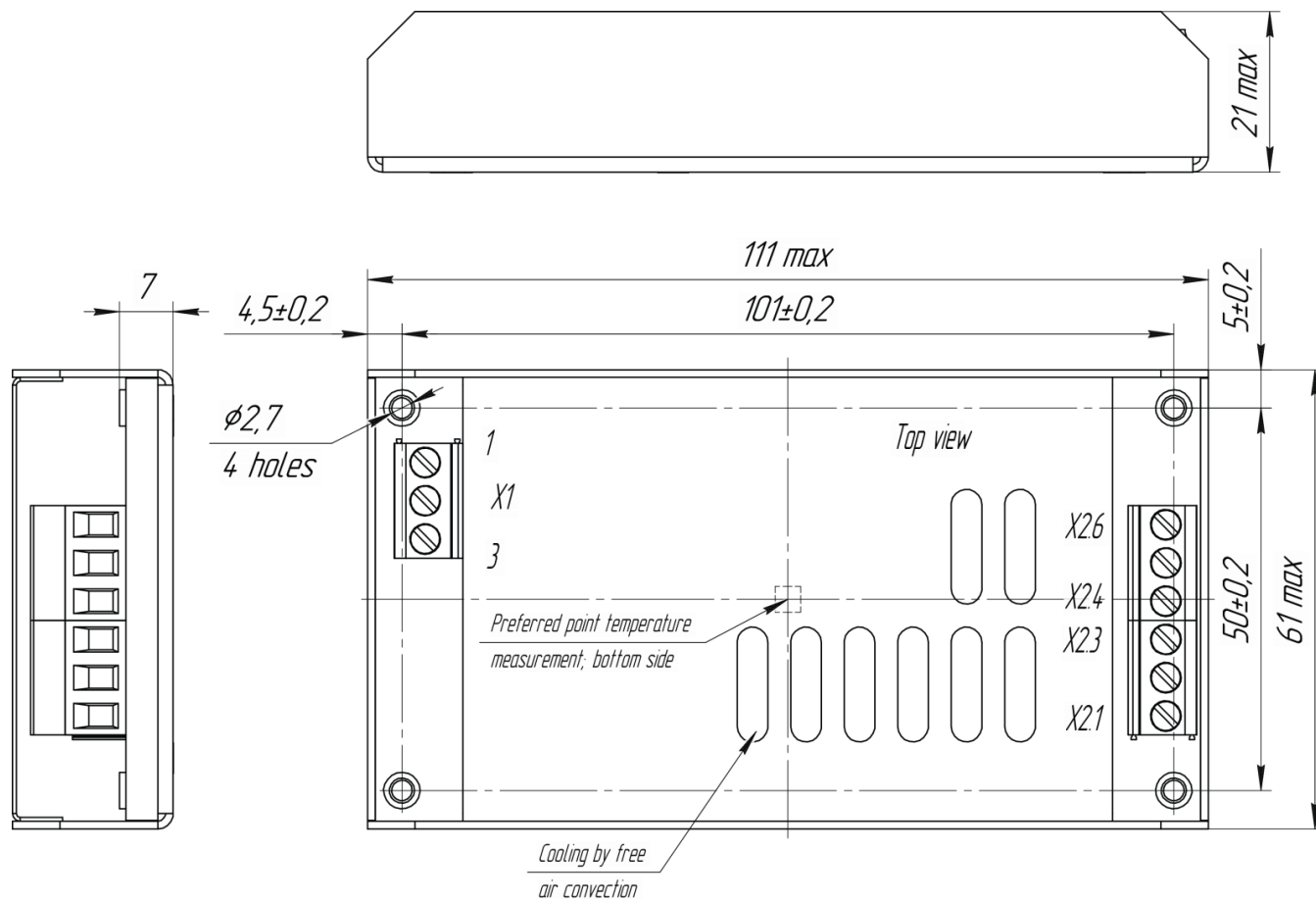

Triple output model with terminal blocks (II A case size)

<p>X1 X2.1...X2.6</p>	<p>RATED WIRE SIZE SOLID: max.: 3.3mm² Stranded (flexible): max.: 3.3mm² Stranded with Ferrule: max 3.3mm² Screw size: M3 Torque: 0,5 Nm</p>
---------------------------	--

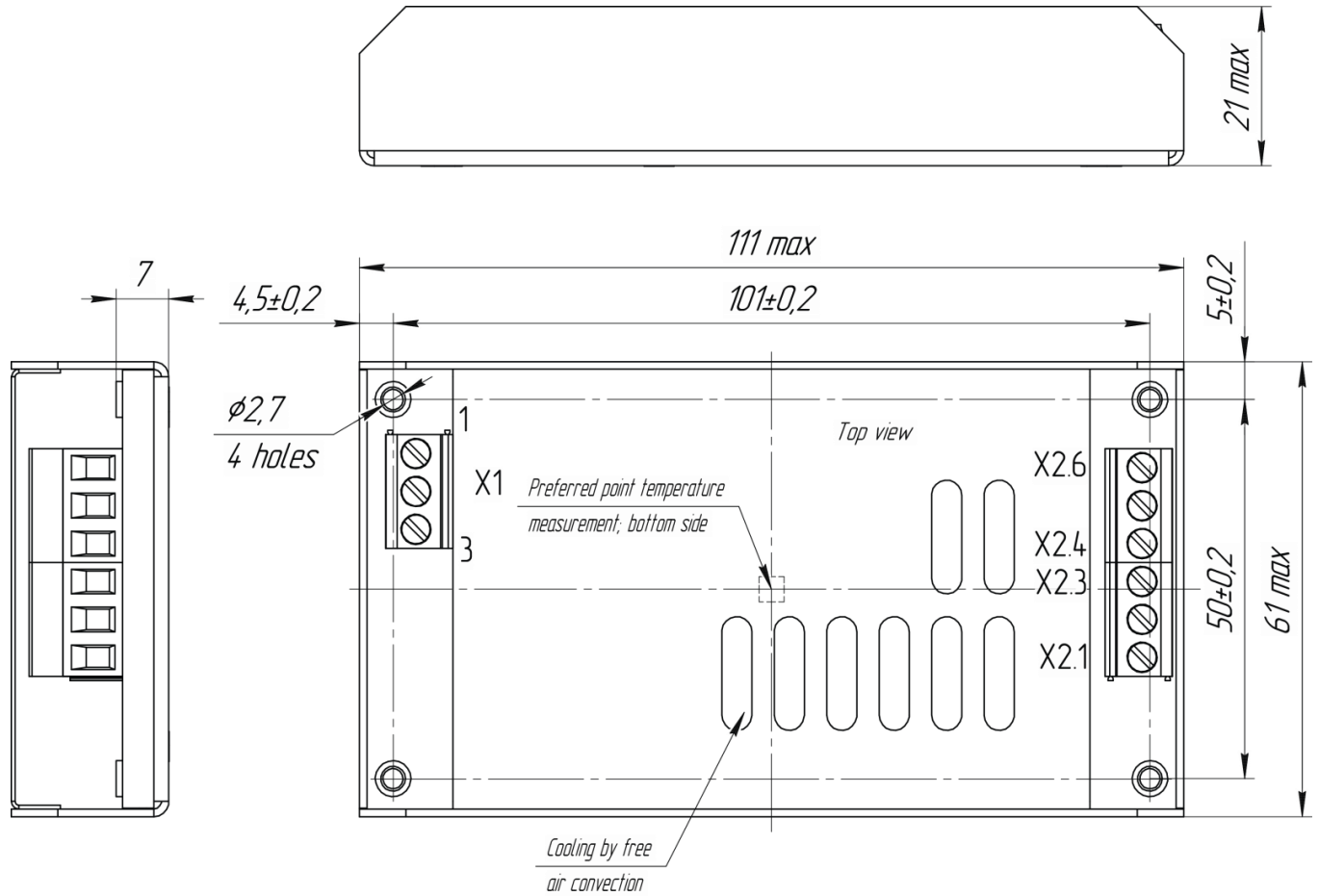

Case with capability of DIN mounting (EN50022-35x15/7.5)

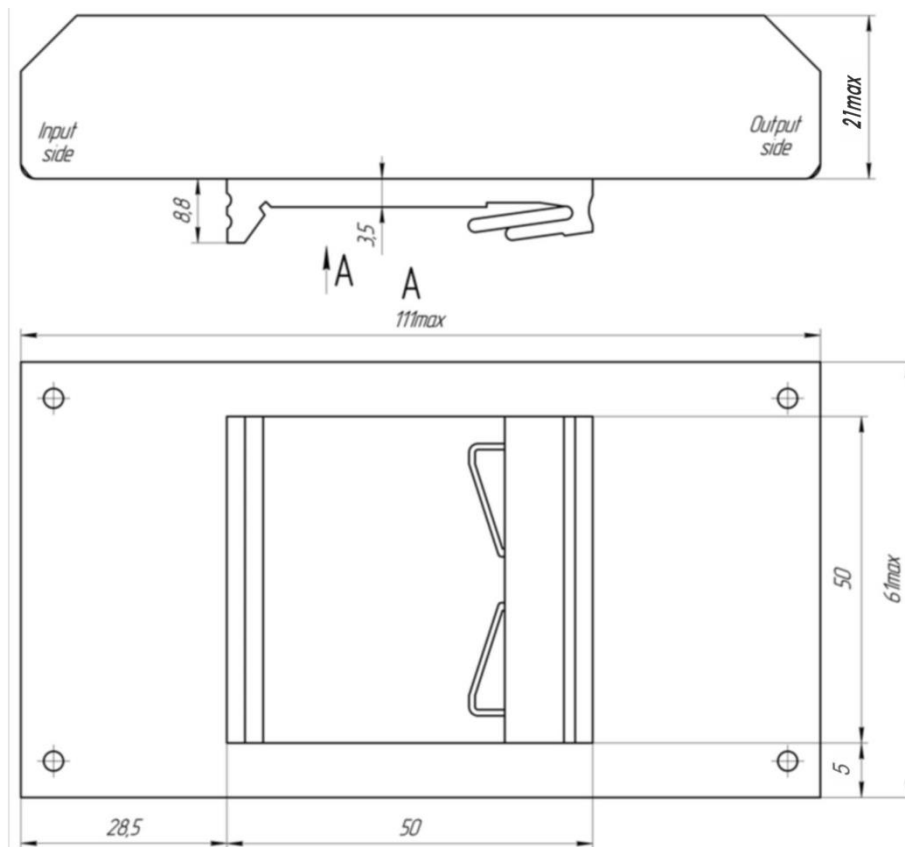

Certificates

Certificate ISO 9001*
CE conformity declaration

* Management system and R&D of Alexander Electric is ISO certified

Note

The input, output and service pins connections of these power supplies are made through blade solder pins either by using standard female terminals or soldering.
The module's connection to the equipment with screw terminals allows the possibility to organize fast installation and easy change of modules during tests or operation in equipments that are not influenced by vibration or aggressive environments.
The module's connection to the equipment by soldering the blade solder pins of flexible wires ensures maximum reliability and minimum voltage drop under effect of adverse mechanical, climatic and chemical factors.
Blade solder pins' modules do not require service of connections (commonly known as periodic tightening of screw terminals) during module's entire life time. This provides more convenience during operation and is a major advantage of these products.

Please, note that all information in this material is for reference only. Further detailed information (including: additional requirements, manuals and circuit schemes) is found on our website <http://www.teslaelectric-eu.com>.

Contact information

<http://www.teslaelectric-eu.com>, e-mail: contact@teslaelectric-eu.com, phone/fax: +420 281 001 341

According to company's policy in view of constant improvements of the production design the manufacturer reserves the right to itself change the contents of promotional materials without prior notification.